



***GT25Q40/20/10/05D***

---

**GT25Q40/20/10/05D**

**4M/2M/1M/512K Bits**  
**SPI Nor Flash**

Copyright © 2014 Giantec Semiconductor Corp. (Giantec). All rights reserved. Giantec reserves the right to make changes to this specification and its products at any time without notice. Giantec products are not designed, intended, authorized or warranted for use as components in systems or equipment intended for critical medical or surgical equipment, aerospace or military, or other applications planned to support or sustain life. It is the customer's obligation to optimize the design in their own products for the best performance and optimization on the functionality and etc. Giantec assumes no liability arising out of the application or use of any information, products or services described herein. Customers are advised to obtain the latest version of this device specification before relying on any published information and prior placing orders for products.

---

***Giantec Semiconductor Corp***

***www.giantec-semi.com***

A0

1/84



# GT25Q40/20/10/05D

## Contents

1.Features	5
2. Genera Description	6
3.Package Types:	7
3.1 Pin Configuration	7
3.2 Pin Description	8
3.3 Chip Select (/CS)	8
3.4 Serial Data Input, Output and IOs (DI, DO and IO0, IO1, IO2, IO3)	8
3.5 Write Protect (/WP)	8
3.6 HOLD (/HOLD)	8
3.7 Serial Clock (CLK)	8
4.BLOCK DIAGRAM	9
5.Memory Architecture Diagram (4Mb)	10
6. ELECTRICAL CHARACTERISTICS	11
6.1 Absolute Maximum Ratings <sup>(1)</sup>	11
6.2 Power-up Timing and Write Inhibit Threshold	11
6.3 Power Up/Down and Voltage Drop	12
6.4 DC Electrical Characteristics: (85°C)	13
6.5 DC Electrical Characteristics: (105°C)	14
6.6 AC Measurement Conditions	15
6.7 AC Characteristics (85°C)	15
6.8 AC Characteristics (105°C)	17
6.9 Serial Output Timing	19
6.10 Serial Input Timing	19
6.11 /HOLD Timing	19
6.12 /WP Timing	19
7 FUNCTIONAL DESCRIPTION	20
7.1 Standard SPI Instructions	20
7.2 Dual SPI Instructions	20
7.3 Quad SPI Instructions	20
7.4 Hold Function	20
7.5 WRITE PROTECTION	21
7.6 Write Protect Features	21
8 STATUS REGISTERS AND INSTRUCTIONS	21
8.1 STATUS REGISTER 1	22
8.1.1 BUSY Status (BUSY)	22
8.1.2 Write Enable Latch Status (WEL)	22
8.1.3 Block Protect Bits (BP2, BP1, BP0)	22
8.1.4 Top/Bottom Block Protect (TB)	22
8.1.5 Sector/Block Protect (SEC)	22
8.1.7 Status Register Protect (SRP0)	23
8.2 STATUS REGISTER 2	23
8.2.1 Erase/Program Suspend Status (SUS)	23
8.2.2 Complement Protect (CMP)	23
8.2.3 Security Register Lock Bit (LB)	24
8.2.4 Quad Enable (QE)	24
8.2.5 Lock Down and OTP (SRP1)	24



# GT25Q40/20/10/05D

8.3 STATUS REGISTER 3 .....	24
8.3.1 Output Driver Strength (DRV1, DRV0).....	25
8.3.2 Reserved Bits .....	25
8.4 Status Register Memory Protection .....	25
9 Commands DESCRIPTION .....	31
9.1 Commands Table .....	31
9.2 Manufacturer and Device Identification.....	33
9.3 Write Enable (WREN) (06h).....	34
9.4 Write Disable (WRDI) (04h) .....	34
9.5 Write Enable for Volatile Status Register (50h).....	35
9.6 Read Status Register (05h/35h/15h).....	35
9.7 Write Status Register (WRSR) (01h/31h/11h).....	36
9.8 Read Data Bytes (READ) (03h) .....	37
9.9 Fast Read (0Bh).....	38
9.10 Dual Output Fast Read (3Bh).....	39
9.11 Quad Output Fast Read (6Bh) .....	40
9.12 Dual I/O Fast Read (BBH) .....	41
9.13 Quad I/O Fast Read (EBH).....	43
9.14 Set Burst with Wrap (77H) .....	45
9.15 Page Program (PP) (02H).....	46
9.16 Quad Page Program (32H).....	47
9.17 Sector Erase (SE) (20H).....	48
9.18 32KB Block Erase (BE) (52H).....	49
9.19 64KB Block Erase (BE) (D8H) .....	50
9.20 Chip Erase (CE) (60/C7H) .....	51
9.21 Deep Power-Down (DP) (B9H) .....	52
9.22 Release from Deep Power-Down and Read Device ID (RDI) (ABH) .....	53
9.23 Read Manufacture ID/ Device ID (REMS) (90H).....	54
9.24 Read Manufacture ID/ Device ID Dual I/O (92H) .....	55
9.25 Read Manufacture ID/ Device ID Quad I/O (94H).....	56
9.26 Read Identification (RDID) (9FH).....	57
9.27 Read Unique ID Number (4Bh).....	58
9.28 Program/Erase Suspend (PES) (75H) .....	59
9.29 Program/Erase Resume (PER) (7AH) .....	60
9.30 Enable Reset (66H) and Reset (99H).....	61
9.31 Read SFDP Register (5Ah).....	62
9.32 Erase Security Registers (44h) .....	69
9.33 Program Security Registers (42h).....	70
9.34 Read Security Registers (48h).....	71
10 Package Information .....	72
10.1 Package SOP8 208MIL .....	72
10.2 Package SOP8 150MIL .....	73
10.3 Package TSSOP8L (173mil).....	74
10.4 Package WSON8 (6*5mm).....	75
10.5 Package WSON8 (4*3mm).....	76
10.6 Package USON8 (2*3mm).....	77
10.7 Package 8Pin USON1.5*1.5 .....	78
10.8 Package 6Pin USON1.2*1.2 .....	79
10.9 Package 6Pin Fan Out CSP .....	80



# **GT25Q40/20/10/05D**

---

11 Ordering Information .....	81
12 Valid Part Numbers and Top Side Marking .....	82
13 REVISION HISTORY .....	84



# GT25Q40/20/10/05D

## 1.Features

- Single Power Supply Voltage
  - Full voltage range: 1.65~3.6V
- Operating Temperature range:
  - -40 to +85 °C
  - -40 to +105 °C
- 4M/2M/1M/512K-bit Serial Flash
  - 512K/256K/128K/64K-byte
  - 256 bytes per programmable page
- Standard, Dual, Quad SPI
  - Standard SPI: CLK, CS#, DI, DO, WP#, HOLD#
  - Dual SPI: CLK, CS#, IO0, IO1, WP#, HOLD#
  - Quad SPI: CLK, CS#, IO0, IO1, IO2, IO3
- High Speed Clock Frequency
  - Max:104MHz for fast read with 30PF load
  - Dual I/O Data transfer up to 208Mbits/s
  - Quad I/O Data transfer up to 416Mbits/s
  - Please refer AC Characteristics for detail value
- Software/Hardware Write Protection
  - Write protect all/portion of memory via software
  - Enable/Disable protection with WP# Pin
  - Top/Bottom Block protection
- Allows XIP (execute in place) Operation
  - Continuous Read With 8/16/32/64-byte Wrap
- Data Retention
  - 20-year data retention typical
- Minimum 100,000 Program/Erase Cycles
- ESD protection (Human Body Model)
  - -4500V to +4500V
- Fast Program/Erase Speed
  - Page Program time: 1.2ms typical
  - Sector Erase time: 2.1ms typical
  - Block Erase time: 2.1ms typical
  - Chip Erase time: 2.1ms typical
- Flexible Architecture
  - Uniform Sector of 4K-byte
  - Uniform Block of 32/64K-byte
  - Erase/Program Suspend/Resume
- Low Power Consumption
  - 8uA typical Standby current
  - 0.25uA typical power down current
- Advanced security Features
  - 4\*256-Byte Security Registers With OTP Lock
  - 64-Bit Unique Serial Number for each device
- Space Efficient Packaging:
  - 8-pin SOIC 208/150 mil
  - 8-pad WSON 6X5 mm
  - 8-pad WSON 4X3 mm
  - 8-pad USON8 2X3 mm
  - 8-pad USON8 1.5X1.5 mm
  - 8-pad USON8 1.2X1.2 mm
  - 8-pin TSSOP
  - 6-pin Fan Out CSP
  - Contact Giantec for KGD and other



# **GT25Q40/20/10/05D**

---

## **2. General Description**

GT25Q40/20/10/05D is 4Mb/2Mb/1Mb/512Kb bits Serial NOR Flash, the array is organized into 2048 programmable pages of 256-bytes each. Up to 256 bytes can be programmed at a time. Pages can be erased in groups of 16 (4KB Sector erase), groups of 128 (32KB block erase), groups of 256 (64KB block erase) or the entire chip (chip erase). The device operates on a single 1.65V to 3.6V power supply with current consumption as low as 1uA Standby current and 0.1μA for power-down. All devices are offered in space-saving packages.

The GT25Q40/20/10/05D supports the standard Serial Peripheral Interface (SPI), and a high performance Dual/Quad output as well as Dual/Quad I/O SPI: Serial Clock, Chip Select, Serial Data I/O0 (DI), I/O1 (DO), I/O2 (/WP), and I/O3 (/HOLD). SPI clock frequencies of up to 104MHz are supported allowing equivalent clock rates of 208MHz (104MHz x 2) for Dual I/O and 416MHz (104MHz x 4) for Quad I/O when using the Fast Read Dual/Quad I/O instructions.

A Hold pin, Write Protect pin and programmable write protection, with top, bottom or complement array control, provide further control flexibility. Additionally, the device supports JEDEC standard manufacturer and device identification with a 64-bit Unique ID. GT25Q40/20/10/05D features a serial peripheral interface and software protocol allowing operation on a simple 3-wire bus while it is in single I/O mode. The three bus signals are a clock input (CLK), a serial data input (DI), and a serial data output (DO). Serial access to the device is enabled by CS# input.



# GT25Q40/20/10/05D

## 3.Package Types:

GT25Q40/20/10/05D is offered in an 8-pin plastic 208mil/150-mil width SOIC (package code W/G), an 8-pad WSON 6X5-mm (package code WS) ,an 8-pad USON 2x3-mm (package code ED), an 8-pad USON1.5\*1.5, an 6-pad USON1.2\*1.2, an 8-pin TSSOP (package code Z) and 6Pin Fan out CSP as below. Package diagrams and dimensions are illustrated at the end of this datasheet.

### 3.1 Pin Configuration

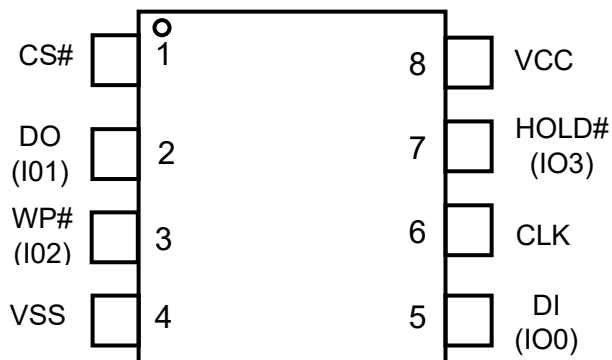

SOP8 208mil/150mil and TSSOP

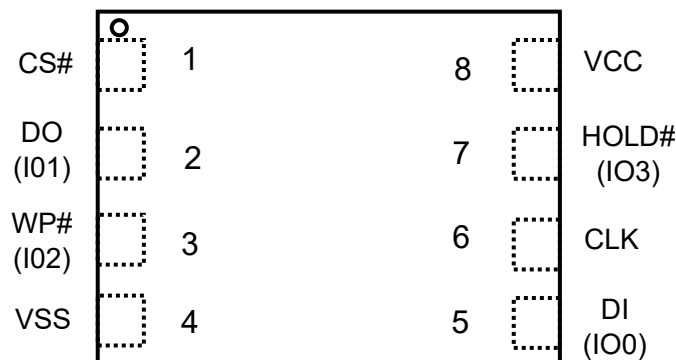

WSON 6x5 / 4x3, USON 2x3 / 1.5\*1.5

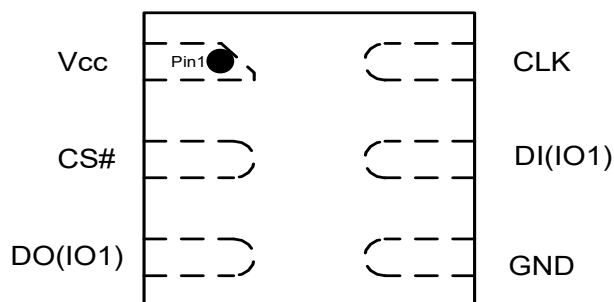

USON1.2\*1.2

Top View

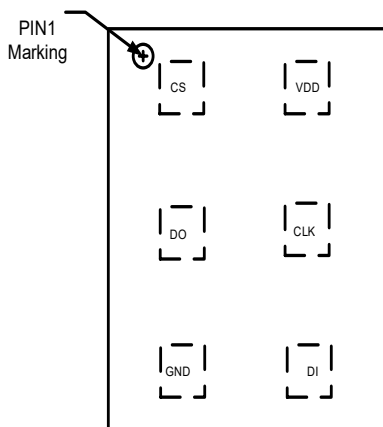

Bottom View

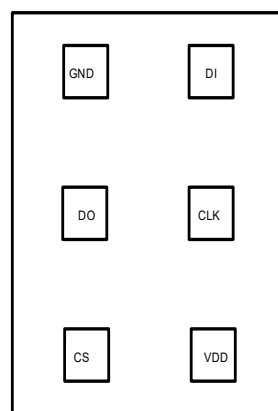

6Pin Fan Out CSP



# GT25Q40/20/10/05D

## 3.2 Pin Description

Pin Name	I/O	Function
/CS	I	Chip Select Input
DO(IO1)	I/O	Data Output (Data Input Output 1)* <sup>1</sup>
/WP(I/O2)	I/O	Write Protect Input (Data Input Output 2)* <sup>2</sup>
GND		Ground
DI(IO0)	I/O	Data Input (Data Input Output 0)* <sup>1</sup>
CLK	I	Serial Clock Input
/HOLD(I/O3)	I/O	Hold Input (Data Input Output 3)* <sup>2</sup>
VCC		Power Supply

## 3.3 Chip Select (/CS)

The SPI Chip Select (/CS) pin enables and disables device operation. When /CS is high the device is deselected and the Serial Data Output (DO, or IO0, IO1, IO2, IO3) pins are at high impedance. When deselected, the device's power consumption will be at standby levels unless an internal erase, program or write status register cycle is in progress. When /CS is brought low the device will be selected, power consumption will increase to active levels and instructions can be written to and data read from the device. After power-up, /CS must transition from high to low before a new instruction will be accepted. The /CS input must track the VCC supply level at power-up (see "Write Protection"). If needed a pull-up resistor on /CS can be used to accomplish this.

## 3.4 Serial Data Input, Output and IOs (DI, DO and IO0, IO1, IO2, IO3)

The GT25Q40/20/10/05D supports standard SPI, Dual SPI and Quad SPI operation. Standard SPI instructions use the unidirectional DI (input) pin to serially write instructions, addresses or data to the device on the rising edge of the Serial Clock (CLK) input pin. Standard SPI also uses the unidirectional DO (output) to read data or status from the device on the falling edge of CLK.

Dual and Quad SPI instructions use the bidirectional IO pins to serially write instructions, addresses or data to the device on the rising edge of CLK and read data or status from the device on the falling edge of CLK. Quad SPI instructions require the non-volatile Quad Enable bit (QE) in Status Register-2 to be set. When QE=1, the /WP pin becomes IO2 and /HOLD pin becomes IO3.

## 3.5 Write Protect (/WP)

The Write Protect (/WP) pin can be used to prevent the Status Register from being written. Used in conjunction with the Status Register's Block Protect (CMP, SEC, TB, BP2, BP1 and BP0) bits and Status Register Protect (SRP) bits, a portion as small as a 4KB sector or the entire memory array can be hardware protected. The /WP pin is active low. When the QE bit of Status Register-2 is set for Quad I/O, the /WP pin function is not available since this pin is used for IO2.

## 3.6 HOLD (/HOLD)

The /HOLD pin allows the device to be paused while it is actively selected. When /HOLD is brought low, while /CS is low, the DO pin will be at high impedance and signals on the DI and CLK pins will be ignored (don't care). When /HOLD is brought high, device operation can resume. The /HOLD function can be useful when multiple devices are sharing the same SPI signals. The /HOLD pin is active low. When the QE bit of Status Register-2 is set for Quad I/O, the /HOLD pin function is not available since this pin is used for IO3. See the pin configuration of Quad I/O operation.

## 3.7 Serial Clock (CLK)

The SPI Serial Clock Input (CLK) pin provides the timing for serial input and output operations. ("See SPI Operations")

Notes:

1. IO0 and IO1 are used for Standard and Dual SPI instructions
2. IO0 – IO3 are used for Quad SPI instructions, /WP & /HOLD functions are only available for Standard/Dual SPI.



# GT25Q40/20/10/05D

## 4. BLOCK DIAGRAM

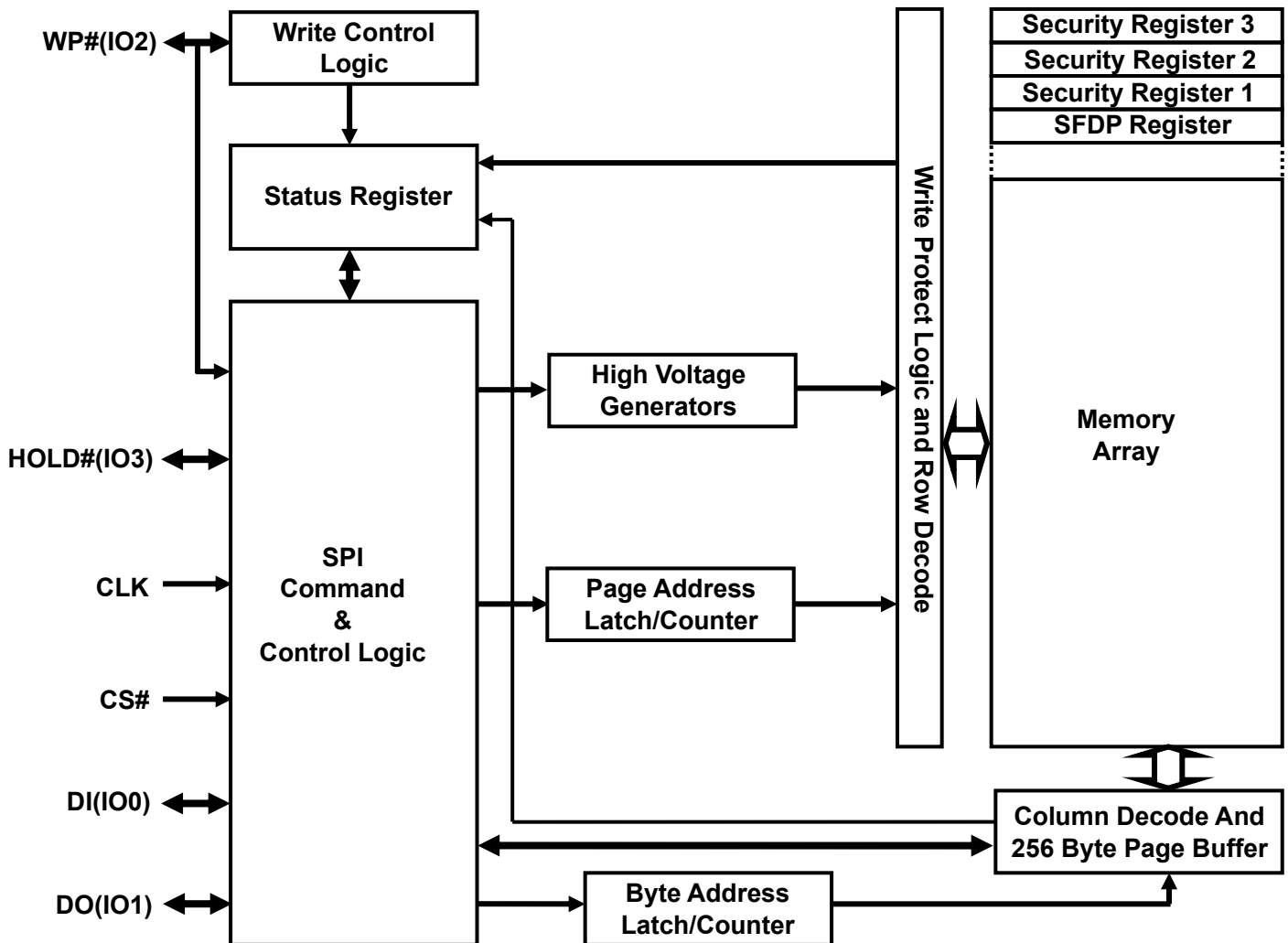



# GT25Q40/20/10/05D

## 5.Memory Architecture Diagram (4Mb)

64KB Block	32KB Block	4KB Block	Block Address Range	256Byte Page	Page Address Range
64KB	32KB	4KB	07FFFFh - 07F000h	256 Bytes	07FFFFh - 07FF00h
		4KB	07EFFFh - 07E000h	256 Bytes	07EFFFh - 07FE00h
		4KB	07DFFFh - 07D000h	256 Bytes	07DFFFh - 07FD00h
		4KB	07CFFFh - 07C000h	256 Bytes	07CFFFh - 07FC00h
		4KB	07BFFFh - 07B000h	256 Bytes	07BFFFh - 07FB00h
		4KB	07AFFFh - 07A000h	256 Bytes	07AFFFh - 07FA00h
		4KB	079FFFh - 079000h	256 Bytes	079FFFh - 07F900h
		4KB	078FFFh - 078000h	256 Bytes	078FFFh - 07F800h
	32KB	4KB	077FFFh - 077000h	256 Bytes	077FFFh - 07F700h
		4KB	076FFFh - 076000h	256 Bytes	076FFFh - 07F600h
		4KB	075FFFh - 075000h	256 Bytes	075FFFh - 07F500h
		4KB	074FFFh - 074000h	256 Bytes	074FFFh - 07F400h
		4KB	073FFFh - 073000h	256 Bytes	073FFFh - 07F300h
		4KB	072FFFh - 072000h	256 Bytes	072FFFh - 07F200h
		4KB	071FFFh - 071000h	256 Bytes	071FFFh - 07F100h
		4KB	070FFFh - 070000h	256 Bytes	070FFFh - 07F000h
.	.	.	.	.	.
64KB	32KB	4KB	00FFFFh - 00F000h	256 Bytes	00FFFFh - 00FF00h
		4KB	00EFFFh - 00E000h	256 Bytes	00EFFFh - 00FE00h
		4KB	00DFFFh - 00D000h	256 Bytes	00DFFFh - 00FD00h
		4KB	00CFFFh - 00C000h	256 Bytes	00CFFFh - 00FC00h
		4KB	00BFFFh - 00B000h	256 Bytes	00BFFFh - 00FB00h
		4KB	00AFFFh - 00A000h	256 Bytes	00AFFFh - 00FA00h
		4KB	009FFFh - 009000h	256 Bytes	009FFFh - 00F900h
		4KB	008FFFh - 008000h	256 Bytes	008FFFh - 00F800h
	32KB	4KB	007FFFh - 007000h	256 Bytes	007FFFh - 00F700h
		4KB	006FFFh - 006000h	256 Bytes	006FFFh - 00F600h
		4KB	005FFFh - 005000h	256 Bytes	005FFFh - 00F500h
		4KB	004FFFh - 004000h	256 Bytes	004FFFh - 00F400h
		4KB	003FFFh - 003000h	256 Bytes	003FFFh - 00F300h
		4KB	002FFFh - 002000h	256 Bytes	002FFFh - 00F200h
		4KB	001FFFh - 001000h	256 Bytes	001FFFh - 00F100h
		4KB	000FFFh - 000000h	256 Bytes	000FFFh - 00F000h



# GT25Q40/20/10/05D

## 6. ELECTRICAL CHARACTERISTICS

### 6.1 Absolute Maximum Ratings<sup>(1)</sup>

PARAMETERS	SYMBOL	CONDITIONS	RANGE	UNIT
Supply Voltage	VCC		-0.6 to VCC+0.6V	V
Voltage Applied to Any Pin	V <sub>IO</sub>	Relative to Ground	-0.6 to VCC+0.4V	V
Transient Voltage on any Pin	V <sub>IO</sub> T	<20nS Transient Relative to Ground	-2.0V to VCC+2.0V	V
Storage Temperature	T <sub>STG</sub>		- 65 to +150 ° C	° C
Ambient Operating Temperature	T <sub>a</sub>		- 40 to +85 ° C	° C
			- 40 to +105 ° C	° C
Electrostatic Discharge Voltage	V <sub>ESD</sub>	Human Body Model <sup>(2)</sup>	- 4500 to +4500 V	V

Notes:

1. This device has been designed and tested for the specified operation ranges. Proper operation outside of these levels is not guaranteed. Exposure to absolute maximum ratings may affect device reliability. Exposure beyond absolute maximum ratings may cause permanent damage.
2. JEDEC Std JESD22-A114A (C1=100pF, R1=1500 ohms, R2=500 ohms).

### 6.2 Power-up Timing and Write Inhibit Threshold

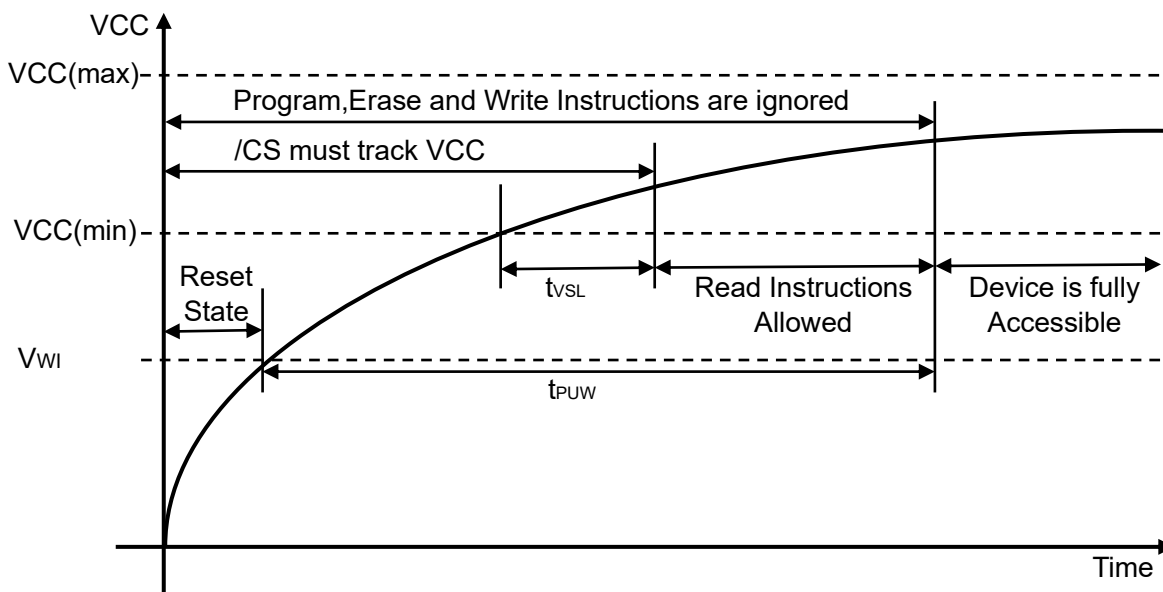

Power-up Timing and Voltage Levels

PARAMETERS	SYMBOL	spec		UNIT
		Min	Max	
VCC (min) to /CS Low	t <sub>VSL</sub> (1)	100		μs
Time Delay Before Write Instruction	t <sub>PUW</sub> (1)	5		ms
Write Inhibit Threshold Voltage	V <sub>wi</sub> (1)	1.2	1.4	V



# GT25Q40/20/10/05D

## 6.3 Power Up/Down and Voltage Drop

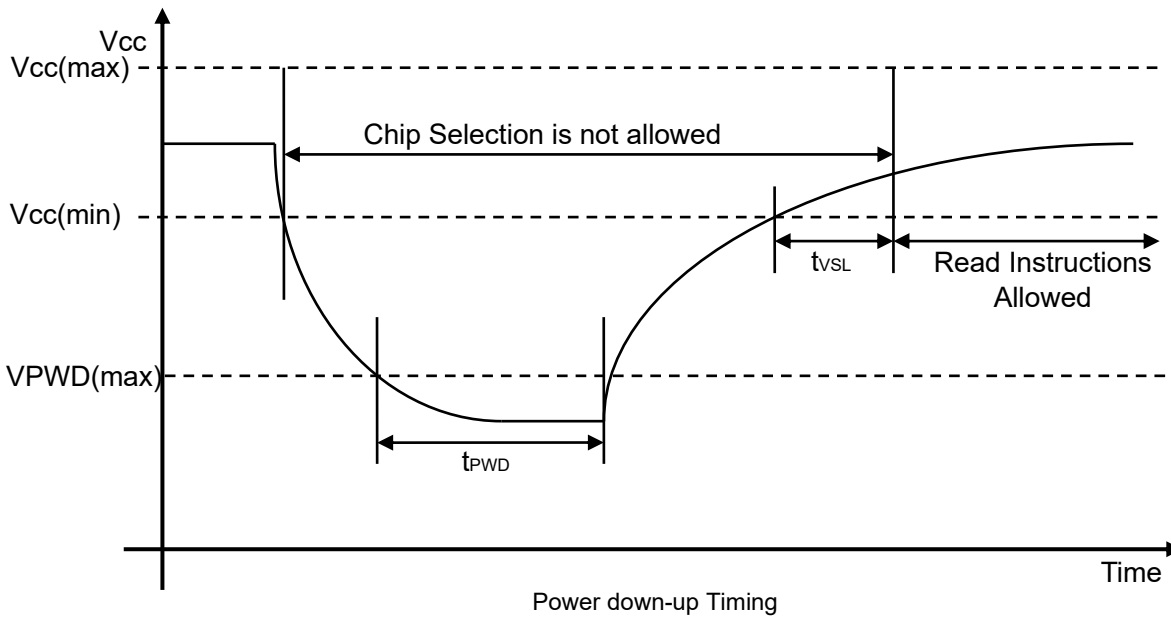
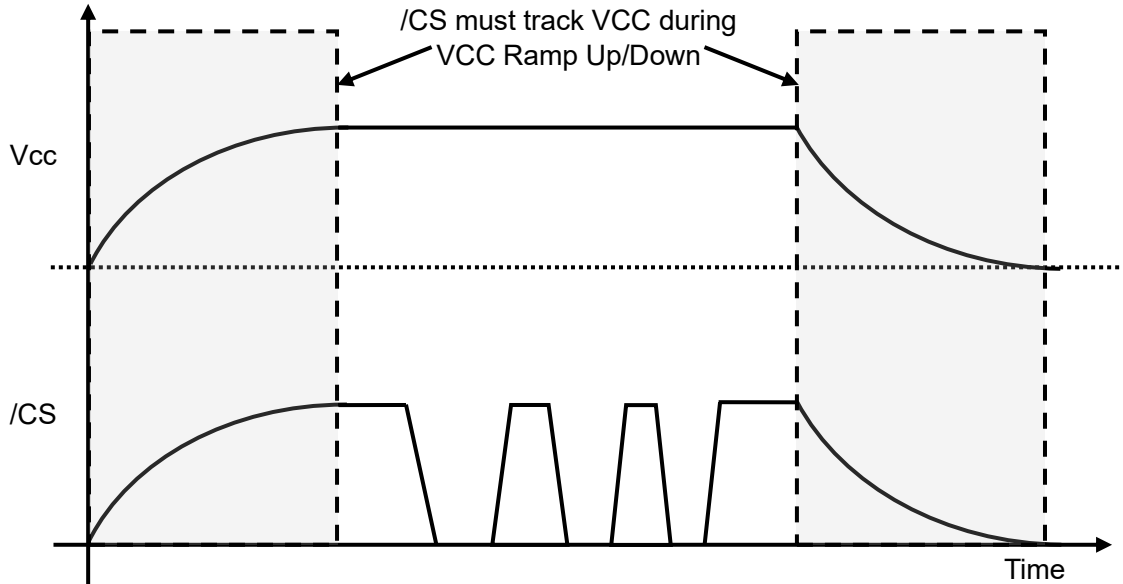

Symbol	Parameter	min	max	unit
VPWD	VCC voltage needed to below VPWD for ensuring initialization will occur		0.8	V
tPVD	The minimum duration for ensuring initialization will occur	300		us
tVR	VCC Rise Time	1	500000	us/V



# GT25Q40/20/10/05D

## 6.4 DC Electrical Characteristics: (85°C)

(Ta= -40°C~85°C, VCC=1.65~3.6V)

Symbol	Parameter	Conditions	1.65 to 2.3V			2.3to 3.6V			Unit
			Min.	Typ.	Max.	Min.	Typ.	Max.	
ISB	Standby Current	CS#=Vcc, all other inputs at 0V or Vcc		8.0	50		8.0	50	μA
IDPD	Deep power down current	CS#=Vcc, all other inputs at 0V or Vcc		0.25	2.0		0.5	5.0	μA
ICC1	Current Read Data(03h) DO=00h	Fr=33MHz DO=Open		1.2	3.0		2.2	6.0	mA
		Fr=50MHz DO=Open		1.8	5.0		3.1	8.0	mA
		Fr=104MHz DO=Open		-	-		5.5	15	mA
ICC3	Program current	CS#=Vcc		0.7	3.0		1.5	5.0	mA
ICC4	Erase Current 4K	CS#=Vcc		0.7	3.0		1.3	5.0	mA
ICC5	Erase Current 32K	CS#=Vcc		0.7	3.0		2.1	5.0	mA
ICC6	Erase Current 64K	CS#=Vcc		0.7	3.0		2.4	5.0	mA
ICC7	Erase Current Chip	CS#=Vcc		0.7	3.0		2.4	5.0	mA
ILI	Input Leakage Current			0.2	0.5		0.2	0.5	μA
ILO	Output Leakage Current			0.2	0.5		0.2	0.5	μA
VIL	Input Low Voltage		-0.5		0.3VCC	-0.5		0.3VCC	V
VIH	Input High Voltage		0.7VCC		VCC+0.4	0.7VCC		VCC+0.4	V
VOL	Output Low Voltage	IOL=100μA			0.2			0.2	V
VOH	Output High Voltage	IOH=-100μA	VCC-0.2			VCC-0.2			V

**Note:**

Typical values measured at 1.8V @ 25°C for the 1.65V to 2.3V range, 3.0V @ 25°C for the 2.3V to 3.6V range, Not 100% tested.



# GT25Q40/20/10/05D

## 6.5 DC Electrical Characteristics: (105°C)

(Ta= -40°C~105°C, VCC=1.65~3.6V)

Symbol	Parameter	Conditions	1.65 to 2.3V			2.3to 3.6V			Unit
			Min.	Typ.	Max.	Min.	Typ.	Max.	
ISB	Standby Current	CS#=Vcc, all other inputs at 0V or Vcc		8.0	100		8.0	150	μA
IDPD	Deep power down current	CS#=Vcc, all other inputs at 0V or Vcc		0.25	6.0		0.5	10	μA
ICC1	Current Read Data(03h) DO=00h	Fr=33MHz DO=Open		1.2	6.0		2.2	10.0	mA
		Fr=50MHz DO=Open		1.5	8.0		3.5	15.0	mA
		Fr=104MHz DO=Open		-	-		5.5	20	mA
ICC3	Program current	CS#=Vcc		0.7	5.0		1.5	8.0	mA
ICC4	Erase Current 4K	CS#=Vcc		0.7	5.0		1.3	8.0	mA
ICC5	Erase Current 32K	CS#=Vcc		0.7	5.0		2.1	8.0	mA
ICC6	Erase Current 64K	CS#=Vcc		0.7	5.0		2.4	8.0	mA
ICC7	Erase Current Chip	CS#=Vcc		0.7	5.0		2.4	8.0	mA
ILI	Input Leakage Current			0.2	0.5		0.2	0.5	μA
ILO	Output Leakage Current			0.2	0.5		0.2	0.5	μA
VIL	Input Low Voltage		-0.5		0.3VCC	-0.5		0.3VCC	V
VIH	Input High Voltage		0.7VCC		VCC+0.4	0.7VCC		VCC+0.4	V
VOL	Output Low Voltage	IOL=100μA			0.2			0.2	V
VOH	Output High Voltage	IOH=-100μA	VCC-0.2			VCC-0.2			V

**Note:**

Typical values measured at 1.8V @ 25°C for the 1.65V to 2.3V range, 3.0V @ 25°C for the 2.3V to 3.6V range, Not 100% tested.



# GT25Q40/20/10/05D

## 6.6 AC Measurement Conditions

PARAMETER	SYMBOL	SPEC		UNIT
		MIN	MAX	
Load Capacitance	CL		30	Pf
Input Rise and Fall Times	TR,TF		5	ns
Input Pulse Voltages	VIN	0.1 VCC to 0.9 VCC		V
Input Timing Reference Voltages	IN	0.3 VCC to 0.7 VCC		V
Output Timing Reference Voltages	OUT	0.5 VCC to 0.5 VCC		V

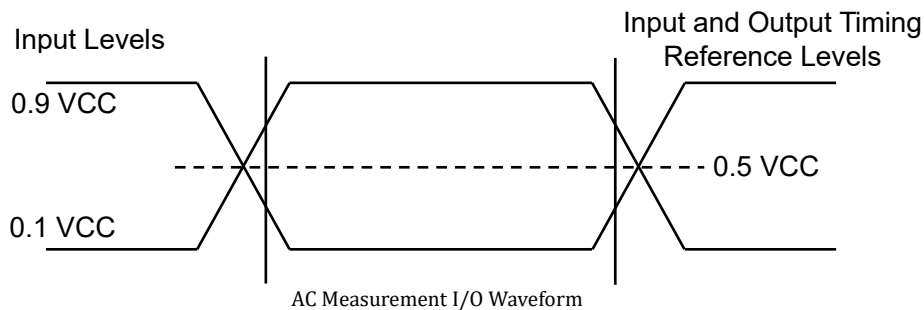

## 6.7 AC Characteristics (85°C)

(Ta = -40°C~85°C, VCC=1.65~3.6V)

Symbol	Description	1.65V~3.6V			Unit
		Min.	Typ.	Max.	
Fr/Fc	Clock frequency for all instructions vdd from 1.65-2.0V for Read Data but except 03h	D.C.		50	MHz
	Clock frequency for all instructions vdd from 2.0-2.7V for Read Data but except 03h	D.C.		70	MHz
	Clock frequency for all instructions vdd from 2.7-3.6V for Read Data but except 03h	D.C.		104	MHz
	Clock frequency for Read Data (03h) vdd from 1.65-2.0V	D.C.		30	MHz
	Clock frequency for Read Data (03h) vdd from 2.0-2.7V	D.C.		30	MHz
	Clock frequency for Read Data (03h) vdd from 2.7-3.6V	D.C.		40	MHz
Tch <sup>(1)</sup>	Clock High Time	45% (1/Fc)			ns
Tcl <sup>(1)</sup>	Clock Low Time	45% (1/Fc)			ns
Tclch <sup>(4)</sup>	Clock Rise Time peak to peak	0.1			V/ns
Tchcl <sup>(4)</sup>	Clock Fall Time peak to peak	0.1			V/ns
Tslch	CS# Active Setup Time (relative to CLK, Vcc=2.3v~3.6v)	7			ns
	CS# Active Setup Time (relative to CLK, Vcc=1.65v~2.3v)	10			ns
Tchsl	CS# Not Active Hold Time (relative to CLK)	5			ns
Tdvch	Data In Setup Time	2			ns



# GT25Q40/20/10/05D

Tchdx	Data In Hold Time	4			ns
Tchsh	CS# Active Hold Time (relative to CLK)	9			ns
Tshch	CS# Not Active Setup Time (relative to CLK)	7			ns
Tshsl	CS# Deselect Time From Read to next Read	15			ns
	CS# Deselect Time From Erase,Program to Read Status Register	30			ns
Tshqz <sup>(4)</sup>	Output Disable Time			15	ns
Tclqv	Clock Low to Output Valid (Vcc=2.7v~3.6v DR=50%)		4	8	ns
	Clock Low to Output Valid (Vcc=1.65v~2.7v DR=50%)		7	13	ns
Tclqx	Output Hold Time	0			ns
Thlch	HOLD# Active Setup Time (relative to CLK)	5			ns
Tchhh	HOLD# Active Hold Time (relative to CLK)	5			ns
Thhch	HOLD# Not Active Setup Time (relative to CLK)	5			ns
Tchhl	HOLD# Not Active Hold Time (relative to CLK)	5			ns
Thhqx	HOLD# to Output Low-Z			8	ns
Thlqz	HOLD# to Output High-Z			6	ns
Twhsl <sup>(3)</sup>	Write Protect Setup Time	20			ns
Tshwl <sup>(3)</sup>	Write Protect Hold Time	100			ns
Tdp	CS# High to Deep Power-down Mode			3	us
Tres1	CS# High To Standby Mode Without ID Read			30	us
Tres2	CS# High To Standby Mode With ID Read			30	us
Tsus	CS# High to next Instruction after Suspend			70	μs
Trst	CS# High to next Instruction after reset (except chip erase 60/C7h)			30	μs
	CS# High to Chip erase after reset			150	us
Tw	Write Status Register Cycle Time		2.5	5	ms
Tbp	Byte Program Time (First Byte)		100	150	μs
Tpp	Page Program Time		1.2	2.5	ms
Tse	Sector erase time		2.1	8	ms
Tbe1	Block erase time for 32K bytes		2.1	8	ms
Tbe2	Block erase time for 64K bytes		2.1	8	ms
Tce	Chip erase time		2.1	14	ms

**Note:**

1. Tch + Tcl must be greater than or equal to 1/ Frequency.
2. Typical values given for TA=25°C. Not 100% tested.
3. Only applicable as a constraint for a WRSR instruction.
4. The value guaranteed by characterization, not 100% tested in production.



# GT25Q40/20/10/05D

## 6.8 AC Characteristics (105°C)

(Ta = -40°C~105°C, VCC=1.65~3.6V)

Symbol	Description	1.65V~3.6V			Unit
		Min.	Typ.	Max.	
Fr/Fc	Clock frequency for all instructions vdd from 1.65-2.0V for Read Data but except 03h	D.C.		50	MHz
	Clock frequency for all instructions vdd from 2.0-2.7V for Read Data but except 03h	D.C.		70	MHz
	Clock frequency for all instructions vdd from 2.7-3.6V for Read Data but except 03h	D.C.		104	MHz
	Clock frequency for Read Data (03h) vdd from 1.65-2.0V	D.C.		30	MHz
	Clock frequency for Read Data (03h) vdd from 2.0-2.7V	D.C.		30	MHz
	Clock frequency for Read Data (03h) vdd from 2.7-3.6V	D.C.		40	MHz
Tch <sup>(1)</sup>	Clock High Time	45% (1/Fc)			ns
Tcl <sup>(1)</sup>	Clock Low Time	45% (1/Fc)			ns
Tclch <sup>(4)</sup>	Clock Rise Time peak to peak	0.1			V/ns
Tchcl <sup>(4)</sup>	Clock Fall Time peak to peak	0.1			V/ns
Tslch	CS# Active Setup Time (relative to CLK, Vcc=2.3v~3.6v)	7			ns
Tslch*	CS# Active Setup Time (relative to CLK, Vcc=1.65v~2.3v)	10			ns
Tchsl	CS# Not Active Hold Time (relative to CLK)	5			ns
Tdvch	Data In Setup Time	2			ns
Tchdx	Data In Hold Time	4			ns
Tchsh	CS# Active Hold Time (relative to CLK)	9			ns
Tshch	CS# Not Active Setup Time (relative to CLK)	7			ns
Tshsl	CS# Deselect Time From Read to next Read	15			ns
	CS# Deselect Time From Erase,Program to Read Status Register	30			ns
Tshqz <sup>(4)</sup>	Output Disable Time			15	ns
Tclqv	Clock Low to Output Valid (Vcc=2.7v~3.6v DR=50%)		4	9	ns
Tclqv*	Clock Low to Output Valid (Vcc=1.65v~2.7v DR=50%)		7	15	ns
Tclqx	Output Hold Time	0			ns
Thlch	HOLD# Active Setup Time (relative to CLK)	5			ns
Tchhh	HOLD# Active Hold Time (relative to CLK)	5			ns
Thhch	HOLD# Not Active Setup Time (relative to CLK)	5			ns
Tchhl	HOLD# Not Active Hold Time (relative to CLK)	5			ns
Thhqx	HOLD# to Output Low-Z			8	ns
Thlqz	HOLD# to Output High-Z			6	ns
Twhsl <sup>(3)</sup>	Write Protect Setup Time	20			ns
Tshwl <sup>(3)</sup>	Write Protect Hold Time	100			ns



# GT25Q40/20/10/05D

Symbol	Description	1.65V~3.6V			Unit
		Min.	Typ.	Max.	
Tdp	CS# High to Deep Power-down Mode			3	us
Tres1	CS# High To Standby Mode Without ID Read			30	us
Tres2	CS# High To Standby Mode With ID Read			30	us
Tsus	CS# High to next Instruction after Suspend			70	μs
Trst	CS# High to next Instruction after reset (except chip erase 60/C7h)			30	μs
	CS# High to Chip erase after reset			150	us
Tw	Write Status Register Cycle Time		2.5	5	ms
Tbp	Byte Program Time (First Byte)		100	150	μs
Tpp	Page Program Time		1.2	2.5	ms
Tse	Sector erase time		2.1	8	ms
Tbe1	Block erase time for 32K bytes		2.1	8	ms
Tbe2	Block erase time for 64K bytes		2.1	8	ms
Tce	Chip erase time		2.1	14	ms

**Note:**

1. Tch + Tci must be greater than or equal to 1/ Frequency.
2. Typical values given for TA=25°C. Not 100% tested.
3. Only applicable as a constraint for a WRSR instruction.
4. The value guaranteed by characterization, not 100% tested in production.



# GT25Q40/20/10/05D

## 6.9 Serial Output Timing

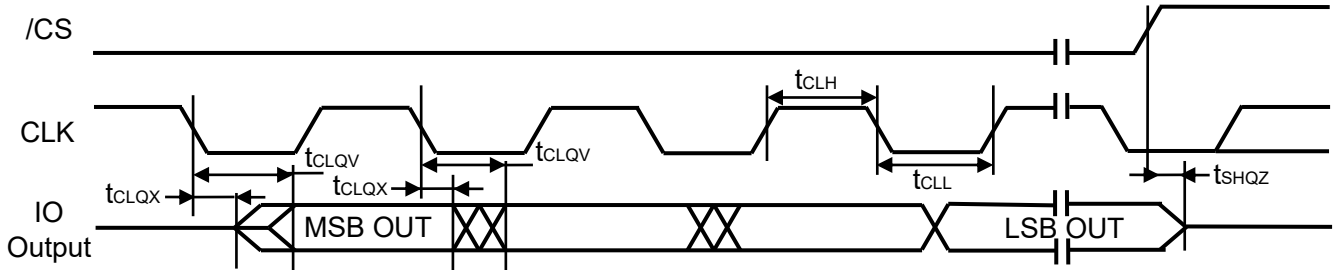

## 6.10 Serial Input Timing

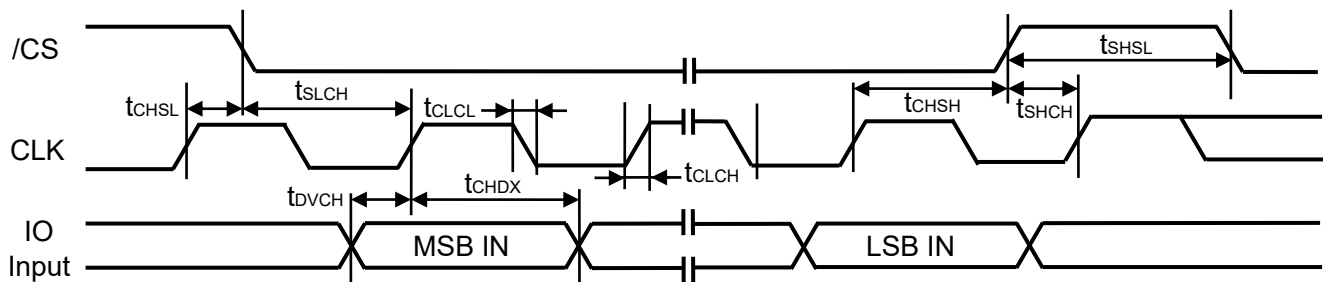

## 6.11 /HOLD Timing

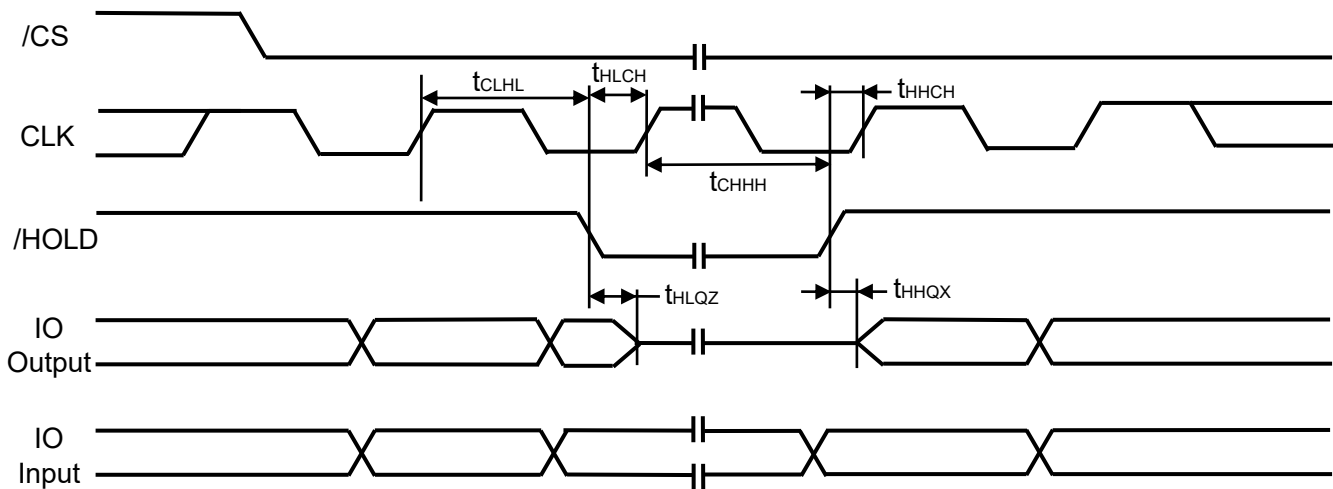

## 6.12 /WP Timing

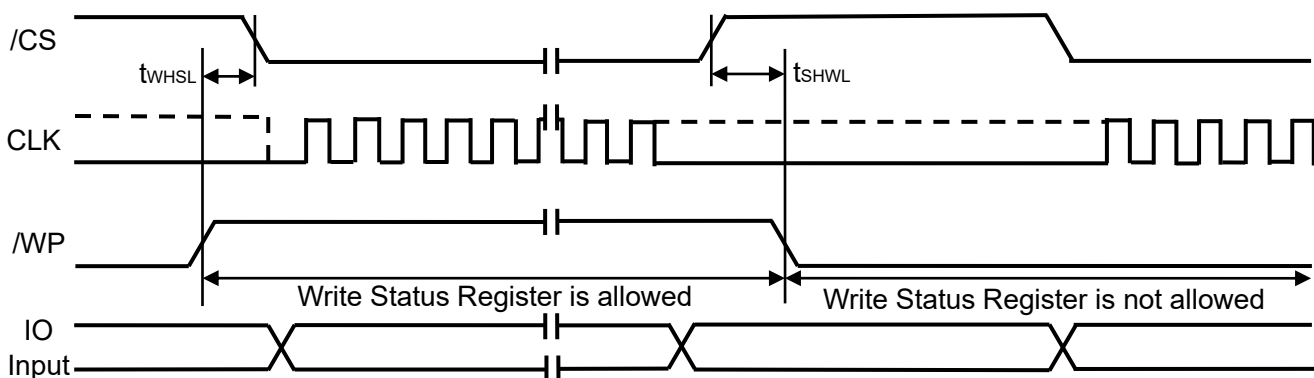



# GT25Q40/20/10/05D

---

## 7 FUNCTIONAL DESCRIPTION

### 7.1 Standard SPI Instructions

The GT25Q40/20/10/05D is accessed through an SPI compatible bus consisting of four signals: Serial Clock (CLK), Chip Select (/CS), Serial Data Input (DI) and Serial Data Output (DO). Standard SPI instructions use the DI input pin to serially write instructions, addresses or data to the device on the rising edge of CLK. The DO output pin is used to read data or status from the device on the falling edge CLK.

SPI bus operation Mode 0 (0,0) and 3 (1,1) are supported. The primary difference between Mode 0 and Mode 3 concerns the normal state of the CLK signal when the SPI bus master is in standby and data is not being transferred to the Serial Flash. For Mode 0, the CLK signal is normally low on the falling and rising edges of /CS. For Mode 3, the CLK signal is normally high on the falling and rising edges of /CS.

### 7.2 Dual SPI Instructions

The GT25Q40/20/10/05D supports Dual SPI operation when using the “Fast Read Dual Output (3Bh)” and “Fast Read Dual I/O (BBh)” instructions. These instructions allow data to be transferred to or from the device at two to three times the rate of ordinary Serial Flash devices. The Dual SPI Read instructions are ideal for quickly downloading code to RAM upon power-up (code-shadowing) or for executing non-speed-critical code directly from the SPI bus (XIP). When using Dual SPI instructions, the DI and DO pins become bidirectional I/O pins: IO0 and IO1.

### 7.3 Quad SPI Instructions

The GT25Q40/20/10/05D supports Quad SPI operation when using the “Fast Read Quad Output (6Bh)”, and “Fast Read Quad I/O (EBh)” instructions. These instructions allow data to be transferred to or from the device six to eight times the rate of ordinary Serial Flash. The Quad Read instructions offer a significant improvement in continuous and random access transfer rates allowing fast code-shadowing to RAM or execution directly from the SPI bus (XIP). When using Quad SPI instructions the DI and DO pins become bidirectional IO0 and IO1, and the /WP and /HOLD pins become IO2 and IO3 respectively. Quad SPI instructions require the non-volatile Quad Enable bit (QE) in Status Register-2 to be set.

### 7.4 Hold Function

For Standard SPI and Dual SPI operations, the /HOLD signal allows the GT25Q40/20/10/05D operation to be paused while it is actively selected (when /CS is low). The /HOLD function may be useful in cases where the SPI data and clock signals are shared with other devices. For example, consider if the page buffer was only partially written when a priority interrupt requires use of the SPI bus. In this case the /HOLD function can save the state of the instruction and the data in the buffer so programming can resume where it left off once the bus is available again. The /HOLD function is only available for standard SPI and Dual SPI operation, not during Quad SPI. The Quad Enable Bit QE in Status Register-2 is used to determine if the pin is used as /HOLD pin or data I/O pin. When QE=0 (factory default), the pin is /HOLD, when QE=1, the pin will become an I/O pin, /HOLD function is no longer available.

To initiate a /HOLD condition, the device must be selected with /CS low. A /HOLD condition will activate on the falling edge of the /HOLD signal if the CLK signal is already low. If the CLK is not already low the /HOLD condition will activate after the next falling edge of CLK. The /HOLD condition will terminate on the rising edge of the /HOLD signal if the CLK signal is already low. If the CLK is not already low the /HOLD condition will terminate after the next falling edge of CLK. During a /HOLD condition, the Serial Data Output (DO) is high impedance, and Serial Data Input (DI) and Serial Clock (CLK) are ignored. The Chip Select (/CS) signal should be kept active low for the full duration of the /HOLD operation to avoid resetting the internal logic state of the device.



# GT25Q40/20/10/05D

---

## 7.5 WRITE PROTECTION

Applications that use non-volatile memory must take into consideration the possibility of noise and other adverse system conditions that may compromise data integrity. To address this concern, the GT25Q40/20/10/05D provides several means to protect the data from inadvertent writes.

### 7.6 Write Protect Features

- Device resets when VCC is below threshold
- Time delay write disable after Power-up
- Write enable/disable instructions and automatic write disable after erase or program
- Software and Hardware (/WP pin) write protection using Status Register
- Write Protection using Power-down instruction
- Lock Down write protection until next power-up
- One Time Program (OTP) write protection\*

\* Note: This feature is available upon special order. Please contact Giantec for details.

Upon power-up or at power-down, the GT25Q40/20/10/05D will maintain a reset condition while VCC is below the threshold value of VWI, (See Power-up Timing and Voltage Levels). While reset, all operations are disabled and no instructions are recognized. During power-up and after the VCC voltage exceeds VWI, all program and erase related instructions are further disabled for a time delay of Tpuw. This includes the Write Enable, Page Program, Sector Erase, Block Erase, Chip Erase and the Write Status Register instructions. Note that the chip select pin (/CS) must track the VCC supply level at power-up until the VCC-min level and Tvs1 time delay is reached. If needed a pull-up resistor on /CS can be used to accomplish this.

After power-up the device is automatically placed in a write-disabled state with the Status Register Write Enable Latch (WEL) set to a 0. A Write Enable instruction must be issued before a Page Program, Sector Erase, Block Erase, Chip Erase or Write Status Register instruction will be accepted. After completing a program, erase or write instruction the Write Enable Latch (WEL) is automatically cleared to a write-disabled state of 0.

Software controlled write protection is facilitated using the Write Status Register instruction and setting the Status Register Protect (SRP, SRL) and Block Protect (CMP, SEC, TB, BP2, BP1 and BP0) bits. These settings allow a portion as small as 4KB sector or the entire memory array to be configured as read only. Used in conjunction with the Write Protect (/WP) pin, changes to the Status Register can be enabled or disabled under hardware control. See Status Register section for further information. Additionally, the Power-down instruction offers an extra level of write protection as all instructions are ignored except for the Release Power-down instruction.

## 8 STATUS REGISTERS AND INSTRUCTIONS

The Read Status Register-1 and Status Register-2 instructions can be used to provide status on the availability of the Flash memory array, if the device is write enabled or disabled, the state of write protection, Quad SPI setting, Security Register lock status and Erase/Program Suspend status. The Write Status Register instruction can be used to configure the device write protection features, Quad SPI setting and Security Register OTP lock. Write access to the Status Register is controlled by the state of the non-volatile Status Register Protect bits (SRP, SRL), the Write Enable instruction, and during Standard/Dual SPI operations, the /WP pin.



# GT25Q40/20/10/05D

## 8.1 STATUS REGISTER 1

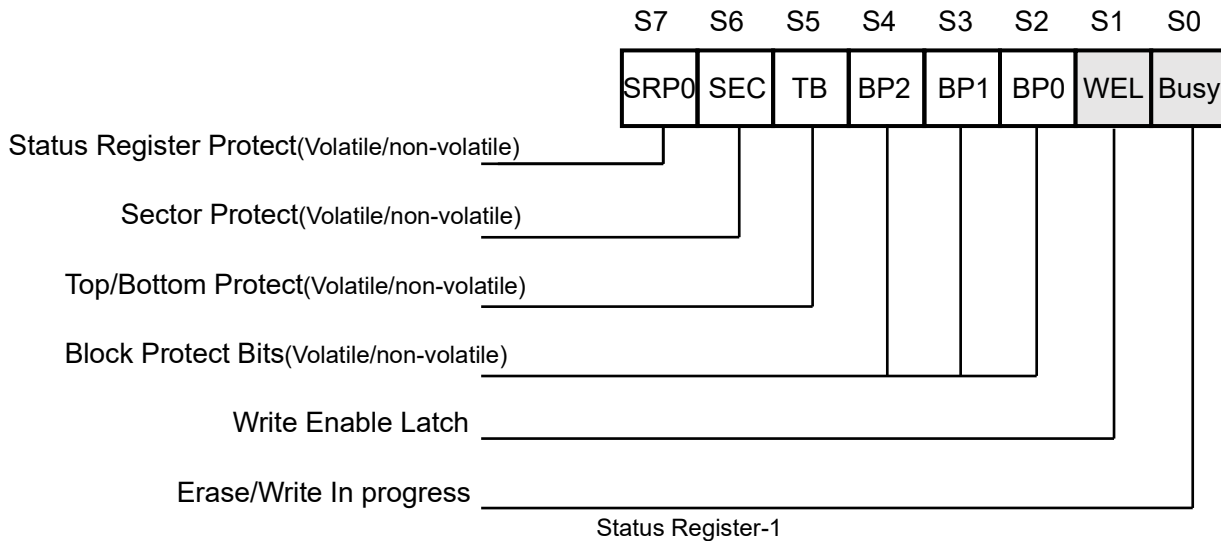

### 8.1.1 BUSY Status (BUSY)

BUSY is a read only bit in the status register (S0) that is set to a 1 state when the device is executing a Page Program, Quad Page Program, Sector Erase, Block Erase, Chip Erase, Write Status Register or Erase/Program Security Register instruction. During this time the device will ignore further instructions except for the Read Status Register and Erase/Program Suspend instruction (see Tw, Tpp, Tse, Tbe, and Tce in AC Characteristics), and each Read Status Register must pull down and up CS#. When the program, erase or write status/security register instruction has completed, the BUSY bit will be cleared to a 0 state indicating the device is ready for further instructions.

### 8.1.2 Write Enable Latch Status (WEL)

Write Enable Latch (WEL) is a read only bit in the status register (S1) that is set to 1 after executing a Write Enable Instruction. The WEL status bit is cleared to 0 when the device is write disabled. A write disable state occurs upon power-up or after any of the following instructions: Write Disable, Page Program, Quad Page Program, Sector Erase, Block Erase, Chip Erase, Write Status Register, Erase Security Register and Program Security Register.

### 8.1.3 Block Protect Bits (BP2, BP1, BP0)

The Block Protect Bits (BP2, BP1, BP0) are non-volatile read/write bits in the status register (S4, S3, and S2) that provide Write Protection control and status. Block Protect bits can be set using the Write Status Register Instruction (see Tw in AC characteristics). All, none or a portion of the memory array can be protected from Program and Erase instructions (see Status Register Memory Protection table). The factory default setting for the Block Protection Bits is 0, none of the array protected.

### 8.1.4 Top/Bottom Block Protect (TB)

The non-volatile Top/Bottom bit (TB) controls if the Block Protect Bits (BP2, BP1, BP0) protect from the Top (TB=0) or the Bottom (TB=1) of the array as shown in the Status Register Memory Protection table. The factory default setting is TB=0. The TB bit can be set with the Write Status Register Instruction depending on the state of the SRP and WEL bits.

### 8.1.5 Sector/Block Protect (SEC)

The non-volatile Sector/Block Protect bit (SEC) controls if the Block Protect Bits (BP2, BP1, BP0) protect either 4KB Sectors (SEC=1) or 64KB Blocks (SEC=0) in the Top (TB=0) or the Bottom (TB=1) of the array as shown in the Status Register Memory Protection table. The default setting is SEC=0.



# GT25Q40/20/10/05D

## 8.1.7 Status Register Protect (SRP0)

The Status Register Protect (SRP1 and SRP0) bits are non-volatile Read/Write bits in the status register. The SRP bits control the method of write protection: software protection, hardware protection, power supply lock-down or one time programmable protection.

SRP1	SRP0	/WP	Status Protection	Description
0	0	X	Software Protection	/WP pin has no control. The Status register can be written to after a Write Enable instruction, WEL=1. [Factory Default]
0	1	0	Hardware Protected	When /WP pin is low the Status Register can not be written to.
0	1	1	Hardware Unprotected	When /WP pin is high the Status register can be written to after a Write Enable instruction, WEL=1.

## 8.2 STATUS REGISTER 2

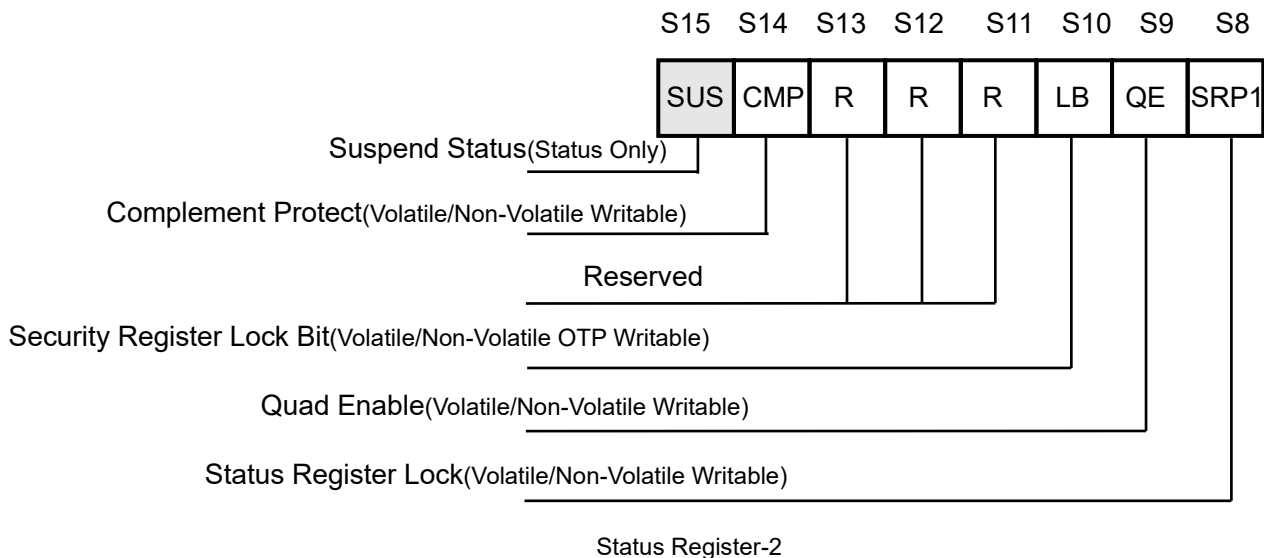

### 8.2.1 Erase/Program Suspend Status (SUS)

The Suspend Status bit is a read only bit in the status register (S15) that is set to 1 after executing a Erase/Program Suspend (75H) instruction. The SUS status bit is cleared to 0 by Erase/Program Resume (7AH) instruction as well as a power-down, power-up cycle.

### 8.2.2 Complement Protect (CMP)

The Complement Protect bit (CMP) is a volatile/non-volatile read/write bit in the status register (S14). It is used in conjunction with SEC, TB, BP2, BP1 and BP0 bits to provide more flexibility for the array protection. Once CMP is set to 1, previous array protection set by SEC, TB, BP2, BP1 and BP0 will be reversed. For instance, when CMP=0, a top 4KB sector can be protected while the rest of the array is not; when CMP=1, the top 4KB sector will become unprotected while the rest of the array become read-only. Please refer to the Status Register Memory Protection table for details. The default setting is CMP=0.



# GT25Q40/20/10/05D

## 8.2.3 Security Register Lock Bit (LB)

The Security Register Lock Bit (LB) is a volatile/non-volatile One Time Program (OTP) bit in the Status Register-2(S10) that provide the write protect control and status to the Security Registers. The default state of LB is 0, Security Registers are unlocked. LB can be set to 1 individually using the Write Status Register instruction. LB are One Time Programmable (OTP), once it's set to 1, the corresponding 4x256-Byte Security Register will become read-only permanently.

## 8.2.4 Quad Enable (QE)

The Quad Enable (QE) bit is a volatile/non-volatile read/write bit in the status register (S9) that allows Quad SPI operation. When the QE bit is set to a 0 state (factory default), the /WP pin and /HOLD are enabled. When the QE bit is set to a 1, the Quad IO2 and IO3 pins are enabled, and /WP and /HOLD functions are disabled.

**WARNING: If the /WP or /HOLD pins are tied directly to the power supply or ground during standard SPI or Dual SPI operation, the QE bit should never be set to a 1.**

## 8.2.5 Lock Down and OTP (SRP1)

The Status Register Protect (SRP1 and SRP0) bits are non-volatile Read/Write bits in the status register. The SRP bits control the method of write protection: software protection, hardware protection, power supply lock-down or one time programmable protection.

SRP1	SRP0	Status Protection	Description
1	0	Lock-Down(1) (temporary/Volatile)	Status Register is locked by standard status register write command and can not be written to again until the next power-down, power-up cycle.
1	1	One Time Program(2) (Permanently/Non-Volatile)	Status Register is permanently locked by special command flow*and can not be written to.

Note:

1. When SRP1=1 , a power-down, power-up cycle will change SRP1=0 state.
2. Special One Time Protection feature is available upon special order; please contact Giantec for details

## 8.3 STATUS REGISTER 3

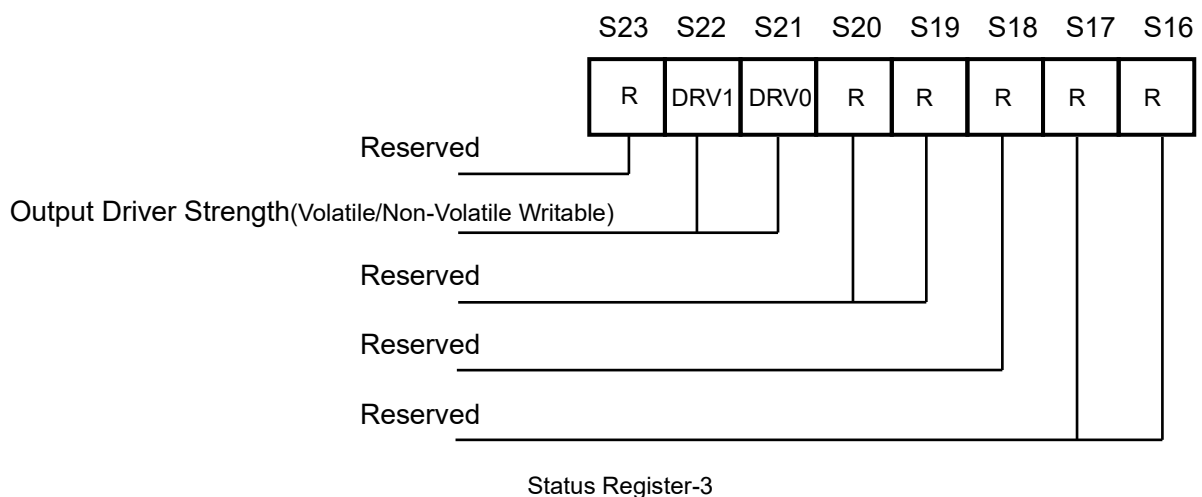



# GT25Q40/20/10/05D

## 8.3.1 Output Driver Strength (DRV1, DRV0)

The DRV1 & DRV0 bits are used to determine the output driver strength for the Read operations. Users can adjust this output drive strength according to the actual application voltage to achieve the best voltage/communication rate adaptation effect. Please contact Giantec for Giantec Nor flash Application note.

DRV1	DRV0	Driver Strength
0	0	100%
0	1	50%
1	0	25%
1	1	10%

Note:

- It is recommended to use 100% DRV for 1.8v application, 10% DRV for 3.3v application, and the Default value of S22 and S21 shall be subject to the goods actually received.

## 8.3.2 Reserved Bits

There are a few reserved Status Register bits that may be read out as a “0” or “1”. It is recommended to ignore the values of those bits. During a “Write Status Register” instruction, the Reserved Bits can be written as “0”, but there will not be any effects.

## 8.4 Status Register Memory Protection

Status Register Memory Protection (CMP = 0) Table1

STATUS REGISTER(1)					GT25Q40D (4M-BIT) MEMORY PROTECTION(2)			
SEC	TB	BP 2	BP 1	BP 0	BLOCK(S)	ADDRESSES	DENSITY	PORTION
X	X	0	0	0	NONE	NONE	NONE	NONE
0	0	0	0	1	7	070000h - 07FFFFh	64KB	Upper 1/8
0	0	0	1	0	6 and 7	060000h - 07FFFFh	128KB	Upper 1/4
0	0	0	1	1	4 and 7	040000h - 07FFFFh	256KB	Upper 1/2
0	1	0	0	1	0	000000h - 00FFFFh	64KB	Lower 1/8
0	1	0	1	0	0 and 1	000000h - 01FFFFh	128KB	Lower 1/4
0	1	0	1	1	0 thru 3	000000h - 03FFFFh	256KB	Lower 1/2
0	X	1	X	X	0 thru 7	000000h - 07FFFFh	512KB	ALL
1	0	0	0	1	7	07F000h - 07FFFFh	4KB	Upper 1/128
1	0	0	1	0	7	07E000h - 07FFFFh	8KB	Upper 1/64
1	0	0	1	1	7	07C000h - 07FFFFh	16KB	Upper 1/32
1	0	1	0	X	7	078000h - 07FFFFh	32KB	Upper 1/16
1	0	1	1	0	7	078000h - 07FFFFh	32KB	Upper 1/16
1	1	0	0	1	0	000000h - 000FFFh	4KB	Lower 1/128
1	1	0	1	0	0	000000h - 001FFFh	8KB	Lower 1/64
1	1	0	1	1	0	000000h - 003FFFh	16KB	Lower 1/32
1	1	1	0	X	0	000000h - 007FFFh	32KB	Lower 1/16
1	1	1	1	0	0	000000h - 007FFFh	32KB	Lower 1/16
1	X	1	1	1	0 thru 7	000000h - 07FFFFh	512KB	ALL

Notes:



# GT25Q40/20/10/05D

1. X = don't care
2. If any Erase or Program command specifies a memory region that contains protected data portion, this command will be ignored.

**Status Register Memory Protection (CMP = 1) Table 2**

STATUS REGISTER(1)					GT25Q40D (4M-BIT) MEMORY PROTECTION(2)			
SEC	TB	BP 2	BP 1	BP0	BLOCK(S)	ADDRESSES	DENSITY	PORTION
X	X	0	0	0	0 thru 7	000000h - 07FFFFh	512KB	ALL
0	0	0	0	1	0 thru 6	000000h - 06FFFFh	448KB	Lower 7/8
0	0	0	1	0	0 thru 5	000000h - 05FFFFh	384KB	Lower 3/4
0	0	0	1	1	0 thru 3	000000h - 03FFFFh	256KB	Lower 1/2
0	1	0	0	1	1 thru 7	010000h - 07FFFFh	448KB	Upper 7/8
0	1	0	1	0	2 thru 7	020000h - 07FFFFh	384KB	Upper 3/4
0	1	0	1	1	4 thru 7	040000h - 07FFFFh	256KB	Upper 1/2
0	X	1	X	X	NONE	NONE	NONE	NONE
1	0	0	0	1	0 thru 7	000000h - 07EFFFh	508KB	Lower 127/128
1	0	0	1	0	0 thru 7	000000h - 07DFFFh	504KB	Lower 63/64
1	0	0	1	1	0 thru 7	000000h - 07BFFFh	496KB	Lower 31/32
1	0	1	0	X	0 thru 7	000000h - 077FFFh	480KB	Lower 15/16
1	0	1	1	0	0 thru 7	000000h - 077FFFh	480KB	Lower 15/16
1	1	0	0	1	0 thru 7	001000h - 07FFFFh	508KB	Upper 127/128
1	1	0	1	0	0 thru 7	002000h - 07FFFFh	504KB	Upper 63/64
1	1	0	1	1	0 thru 7	004000h - 07FFFFh	496KB	Upper 31/32
1	1	1	0	X	0 thru 7	008000h - 07FFFFh	480KB	Upper 15/16
1	1	1	1	0	0 thru 7	008000h - 07FFFFh	480KB	Upper 15/16
X	X	1	1	1	NONE	NONE	NONE	NONE

Notes:

1. X = don't care
2. If any Erase or Program command specifies a memory region that contains protected data portion, this command will be ignored.



# GT25Q40/20/10/05D

**Status Register Memory Protection (CMP = 0) Table3**

STATUS REGISTER(1)					GT25Q20D (2M-BIT) MEMORY PROTECTION(2)			
SEC	TB	BP2	BP1	BP0	BLOCK(S)	ADDRESSES	DENSITY	PORTION
0	X	X	0	0	NONE	NONE	NONE	NONE
0	0	X	0	1	3	030000h - 03FFFFh	64KB	Upper 1/4
0	0	X	1	0	2 and 3	020000h - 03FFFFh	128KB	Upper 1/2
0	1	X	0	1	0	000000h - 00FFFFh	64KB	Lower 1/4
0	1	X	1	0	0 and 1	000000h - 01FFFFh	128KB	Lower 1/2
0	X	X	1	1	0 thru 3	000000h - 03FFFFh	256KB	ALL
1	X	0	0	0	NONE	NONE	NONE	NONE
1	0	0	0	1	3	03F000h - 03FFFFh	4KB	Upper 1/64
1	0	0	1	0	3	03E000h - 03FFFFh	8KB	Upper 1/32
1	0	0	1	1	3	03C000h - 03FFFFh	16KB	Upper 1/16
1	0	1	0	X	3	038000h - 03FFFFh	32KB	Upper 1/8
1	0	1	1	0	3	038000h - 03FFFFh	32KB	Upper 1/8
1	1	0	0	1	0	000000h - 00FFFFh	4KB	Lower 1/64
1	1	0	1	0	0	000000h - 001FFFh	8KB	Lower 1/32
1	1	0	1	1	0	000000h - 003FFFh	16KB	Lower 1/16
1	1	1	0	X	0	000000h - 007FFFh	32KB	Lower 1/8
1	1	1	1	0	0	000000h - 007FFFh	32KB	Lower 1/8
1	X	1	1	1	0 thru 3	000000h - 03FFFFh	256KB	ALL

**Notes:**

1. X = don't care
2. If any Erase or Program command specifies a memory region that contains protected data portion, this command will be ignored.



# GT25Q40/20/10/05D

**Status Register Memory Protection (CMP = 1)Table4**

STATUS REGISTER(1)					GT25Q20D (2M-BIT) MEMORY PROTECTION(2)			
SEC	TB	BP2	BP1	BP0	BLOCK(S)	ADDRESSES	DENSITY	PORTION
0	X	X	0	0	0 thru 3	000000h - 03FFFFh	256KB	ALL
0	0	X	0	1	0 thru 2	000000h - 02FFFFh	192KB	Lower 3/4
0	0	X	1	0	0 and 1	000000h - 01FFFFh	128KB	Lower 1/2
0	1	X	0	1	0 thru 3	010000h - 03FFFFh	192KB	Upper 3/4
0	1	X	1	0	2 and 3	020000h - 03FFFFh	128KB	Upper 1/2
0	X	X	1	1	NONE	NONE	NONE	NONE
1	X	0	0	0	0 thru 3	000000h - 03FFFFh	256KB	ALL
1	0	0	0	1	0 thru 3	000000h - 03EFFFh	252KB	Lower 63/64
1	0	0	1	0	0 thru 3	000000h - 03DFFFh	248KB	Lower 31/32
1	0	0	1	1	0 thru 3	000000h - 03BFFFh	240KB	Lower 15/16
1	0	1	0	X	0 thru 3	000000h - 037FFFh	224KB	Lower 7/8
1	0	1	1	0	0 thru 3	000000h - 037FFFh	224KB	Lower 7/8
1	1	0	0	1	0 thru 3	001000h - 03FFFFh	252KB	Upper 63/64
1	1	0	1	0	0 thru 3	002000h - 03FFFFh	248KB	Upper 31/32
1	1	0	1	1	0 thru 3	004000h - 03FFFFh	240KB	Upper 15/16
1	1	1	0	X	0 thru 3	008000h - 03FFFFh	224KB	Upper 7/8
1	1	1	1	0	0 thru 3	008000h - 03FFFFh	224KB	Upper 7/8
1	X	1	1	1	NONE	NONE	NONE	NONE

**Notes:**

1. X = don't care
2. If any Erase or Program command specifies a memory region that contains protected data portion, this command will be ignored.



# GT25Q40/20/10/05D

**Status Register Memory Protection (CMP = 0) Table5**

STATUS REGISTER(1)					GT25Q10D (1M-BIT) MEMORY PROTECTION(2)			
SEC	TB	BP2	BP1	BP0	BLOCK(S)	ADDRESSES	DENSITY	PORTION
0	X	X	0	0	NONE	NONE	NONE	NONE
0	0	X	0	1	1	010000h - 01FFFFh	64KB	Upper 1/2
0	1	X	0	1	0	000000h - 00FFFFh	64KB	Lower 1/2
0	X	X	1	X	0 thru 1	000000h - 01FFFFh	128KB	ALL
1	X	0	0	0	NONE	NONE	NONE	NONE
1	0	0	0	1	1	01F000h - 01FFFFh	4KB	Upper 1/32
1	0	0	1	0	1	01E000h - 01FFFFh	8KB	Upper 1/16
1	0	0	1	1	1	01C000h - 01FFFFh	16KB	Upper 1/8
1	0	1	0	X	1	018000h - 01FFFFh	32KB	Upper 1/4
1	0	1	1	0	1	018000h - 01FFFFh	32KB	Upper 1/4
1	1	0	0	1	0	000000h - 000FFFh	4KB	Lower 1/32
1	1	0	1	0	0	000000h - 001FFFh	8KB	Lower 1/16
1	1	0	1	1	0	000000h - 003FFFh	16KB	Lower 1/8
1	1	1	0	X	0	000000h - 007FFFh	32KB	Lower 1/4
1	1	1	1	0	0	000000h - 007FFFh	32KB	Lower 1/4
1	X	1	1	1	0 thru 1	000000h - 01FFFFh	128KB	ALL

**Status Register Memory Protection (CMP = 1) Table6**

STATUS REGISTER(1)					GT25Q10D (1M-BIT) MEMORY PROTECTION(2)			
SEC	TB	BP2	BP1	BP0	BLOCK(S)	ADDRESSES	DENSITY	PORTION
0	X	X	0	0	0 thru 1	000000h - 01FFFFh	ALL	ALL
0	0	X	0	1	0	000000h - 00FFFFh	64KB	Lower 1/2
0	1	X	0	1	1	010000h - 01FFFFh	64KB	Upper 1/2
0	X	X	1	X	NONE	NONE	NONE	NONE
1	X	0	0	0	0	000000h - 01FFFFh	128KB	ALL
1	0	0	0	1	0	000000h - 01EFFFh	124KB	Lower 31/32
1	0	0	1	0	0	000000h - 01DFFFh	120KB	Lower 15/16
1	0	0	1	1	0	000000h - 01BFFFh	112KB	Lower 7/8
1	0	1	0	X	0	000000h - 017FFFh	96KB	Lower 3/4
1	0	1	1	0	0	000000h - 017FFFh	96KB	Lower 3/4
1	1	0	0	1	1	001000h - 01FFFFh	124KB	Upper 31/32
1	1	0	1	0	1	002000h - 01FFFFh	120KB	Upper 15/16
1	1	0	1	1	1	004000h - 01FFFFh	112KB	Upper 7/8
1	1	1	0	X	1	008000h - 01FFFFh	96KB	Upper 3/4
1	1	1	1	0	1	008000h - 01FFFFh	96KB	Upper 3/4
1	X	1	1	1	NONE	NONE	NONE	NONE

Notes:



# GT25Q40/20/10/05D

1. X = don't care
2. If any Erase or Program command specifies a memory region that contains protected data portion, this command will be ignored.

**Status Register Memory Protection (CMP = 0) Table7**

STATUS REGISTER(1)					GT25Q05D (512K-BIT) MEMORY PROTECTION(2)			
SEC	TB	BP2	BP1	BP0	BLOCK(S)	ADDRESSES	DENSITY	PORTION
0	X	X	0	0	NONE	NONE	NONE	NONE
0	X	X	0	1	0	000000h – 00FFFFh	64KB	ALL
0	X	X	1	X	0	000000h – 00FFFFh	64KB	ALL
1	X	0	0	0	NONE	NONE	NONE	NONE
1	0	0	0	1	0	00F000h – 00FFFFh	4KB	Upper 1/16
1	0	0	1	0	0	00E000h – 00FFFFh	8KB	Upper 1/8
1	0	0	1	1	0	00C000h – 00FFFFh	16KB	Upper 1/4
1	0	1	0	X	0	008000h – 00FFFFh	32KB	Upper 1/2
1	0	1	1	0	0	008000h – 00FFFFh	32KB	Upper 1/2
1	1	0	0	1	0	000000h – 000FFFh	4KB	Lower 1/16
1	1	0	1	0	0	000000h – 001FFFh	8KB	Lower 1/8
1	1	0	1	1	0	000000h – 003FFFh	16KB	Lower 1/4
1	1	1	0	X	0	000000h – 007FFFh	32KB	Lower 1/2
1	1	1	1	0	0	000000h – 007FFFh	32KB	Lower 1/2
1	X	1	1	1	0	000000h – 00FFFFh	64KB	ALL

**Status Register Memory Protection (CMP = 1) Table8**

STATUS REGISTER(1)					GT25Q05D (512K-BIT) MEMORY PROTECTION(2)			
SEC	TB	BP2	BP1	BP0	BLOCK(S)	ADDRESSES	DENSITY	PORTION
0	X	X	0	0	0	000000h - 00FFFFh	64KB	ALL
0	X	X	0	1	NONE	NONE	NONE	NONE
0	X	X	1	X	NONE	NONE	NONE	NONE
1	X	0	0	0	0	000000h - 00FFFFh	64KB	ALL
1	0	0	0	1	0	000000h - 00EFFFh	64KB	Lower 15/16
1	0	0	1	0	0	000000h - 00DFFFh	56KB	Lower 7/8
1	0	0	1	1	0	000000h - 00BFFFh	48KB	Lower 3/4
1	0	1	0	X	0	000000h - 007FFFh	32KB	Lower 1/2
1	0	1	1	0	0	000000h - 007FFFh	32KB	Lower 1/2
1	1	0	0	1	0	001000h - 00FFFFh	60KB	Upper 15/16
1	1	0	1	0	0	002000h - 00FFFFh	56KB	Upper 7/8
1	1	0	1	1	0	004000h - 00FFFFh	48KB	Upper 3/4
1	1	1	0	X	0	008000h - 00FFFFh	32KB	Upper 1/2
1	1	1	1	0	0	008000h - 00FFFFh	32KB	Upper 1/2
1	X	1	1	1	NONE	NONE	NONE	NONE

Notes:

1. X = don't care
2. If any Erase or Program command specifies a memory region that contains protected data portion, this command will be ignored.



# GT25Q40/20/10/05D

## 9 Commands DESCRIPTION

All commands, addresses and data are shifted in and out of the device, beginning with the most significant bit on the first rising edge of CLK after CS# is driven low. Then, the one-byte command code must be shifted in to the device, with most significant bit first on DI, and each bit is latched on the rising edges of CLK.

See below Table, every command sequence starts with a one-byte command code. Depending on the command, this might be followed by address bytes, or by data bytes, or by both or none. CS# must be driven high after the last bit of the command sequence has been completed. For the command of Read, Fast Read, Read Status Register or Release from Deep Power- Down, and Read Device ID, the shifted-in command sequence is followed by a data-out sequence. CS# can be driven high after any bit of the data-out sequence is being shifted out.

For the command of Page Program, Sector Erase, Block Erase, Chip Erase, Write Status Register, Write Enable, Write Disable or Deep Power-Down command, CS# must be driven high exactly at a byte boundary, otherwise the command is rejected, and is not executed. That is CS# must be driven high when the number of clock pulses after CS# being driven low is an exact multiple of eight. For Page Program, if at any time the input byte is not a full byte, nothing will happen and WEL will not be reset.

### 9.1 Commands Table

Command Name	Byte 1	Byte 2	Byte 3	Byte 4	Byte 5	Byte6	Byte7	Byte N
Write Enable	06h							
Write Disable	04h							
Volatile SR Write Enable	50h							
Read Status Register1	05h	S7-S0						continuous
Read Status Register2	35h	S15-S8						continuous
Read Status Register3	15h	S23-S16						continuous
Write Status Register1	01H	S7-S0	S15-S8					
Write Status Register2	31H	S15-S8						
Write Status Register3	11H	S23-S16						
Read Data	03h	A23-A16	A15-A8	A7-A0	(D7-D0)	Next byte		continuous
Fast Read	0Bh	A23-A16	A15-A8	A7-A0	dummy	(D7-D0)		continuous
Dual Output Fast Read	3Bh	A23-A16	A15-A8	A7-A0	dummy	(D7-D0) <sup>(1)</sup>		continuous
Dual I/O Fast Read	BBH	A23-A16 <sup>(2)</sup>	A15-A8 <sup>(2)</sup>	A7-A0 <sup>(2)</sup>	M7-M0 <sup>(2)</sup>	(D7-D0) <sup>(1)</sup>		continuous
Quad Output Fast Read	6BH	A23-A16	A15-A8	A7-A0	dummy	(D7-D0) <sup>(3)</sup>		continuous
Quad I/O Fast Read	EBH	A23-A16 <sup>(4)</sup>	A15-A8 <sup>(4)</sup>	A7-A0 <sup>(4)</sup>	M7-M0 <sup>(4)</sup>	dummy <sup>(5)</sup>	dummy <sup>(5)</sup>	(D7-D0) <sup>(3)</sup>



# GT25Q40/20/10/05D

Command Name	Byte 1	Byte 2	Byte 3	Byte 4	Byte 5	Byte6	Byte7	Byte N
Page Program	02H	A23-A16	A15-A8	A7-A0	(D7-D0)	Next byte		
Quad Page Program	32H	A23-A16	A15-A8	A7-A0	(D7-D0) <sup>(6)</sup>	Next byte		
Sector Erase(4KB)	20H	A23-A16	A15-A8	A7-A0				
Block Erase(32KB)	52H	A23-A16	A15-A8	A7-A0				
Block Erase(64K)	D8H	A23-A16	A15-A8	A7-A0				
Chip Erase	C7/60H							
Enable Reset	66H							
Reset	99H							
Set Burst with Wrap	77H	dummy <sup>(7)</sup>	dummy <sup>(7)</sup>	dummy <sup>(7)</sup>	W6-W4 <sup>(7)</sup>			
Program/Erase Suspend	75H							
Program/Erase Resume	7AH							
Deep Power-Down	B9H							
Release From Deep Power-Down, And Read Device ID	ABH	dummy	dummy	dummy	(ID7-ID0)			continuous
Manufacturer / Device ID	90H	dummy	dummy	00h	(M7-M0)	(ID7-ID0)		continuous
Manufacturer/ Device ID by Dual I/O	92H	A23-A16 <sup>(2)</sup>	A15-A8 <sup>(2)</sup>	A7-A0 <sup>(2)</sup> (00h)	M7-M0 <sup>(2)</sup>	(MID7-MID0)	(ID7-ID0) <sup>(1)</sup>	continuous
Manufacturer/ Device ID by Quad I/O	94H	A23-A16 <sup>(4)</sup>	A15-A8 <sup>(4)</sup>	A7-A0 <sup>(4)</sup>	M7-M0 <sup>(4)</sup>	dummy	dummy	(MID7-MID0)
Read Identification	9FH	(MID7-MID0)	(ID15-ID8)	(ID7-ID0)				continuous
Read Unique ID	4Bh	dummy	dummy	dummy	dummy	UID(63-0)		
Read SFDP Register	5AH	A23-A16	A15-A8	A7-A0	dummy	(D7-D0)	Next byte	continuous
Erase Security Registers	44H	A23-A16	A15-A8	A7-A0				
Program Security Registers	42H	A23-A16	A15-A8	A7-A0	(D7-D0)	Next byte		
Read Security Registers	48H	A23-A16	A15-A8	A7-A0	dummy	D7-D0	Next byte	

NOTE:

1. Dual Output data

IO0 = (D6, D4, D2, D0)



# GT25Q40/20/10/05D

IO1 = (D7, D5, D3, D1)

## 2. Dual Input Address

IO0 = A22, A20, A18, A16, A14, A12, A10, A8      A6, A4, A2, A0, M6, M4, M2, M0

IO1 = A23, A21, A19, A17, A15, A13, A11, A9      A7, A5, A3, A1, M7, M5, M3, M1

## 3. Quad Output Data

IO0 = (D4, D0, .....)

IO1 = (D5, D1, .....)

IO2 = (D6, D2, .....)

IO3 = (D7, D3,.....)

## 4. Quad Input Address

IO0 = A20, A16, A12, A8,    A4, A0, M4, M0

IO1 = A21, A17, A13, A9,    A5, A1, M5, M1

IO2 = A22, A18, A14, A10, A6, A2, M6, M2

IO3 = A23, A19, A15, A11, A7, A3, M7, M3

## 5. Fast Read Quad I/O Data

IO0 = (x, x, x, x, D4, D0,...)

IO1 =(x, x, x, x, D5, D1,...)

IO2 =(x, x, x, x, D6, D2,...)

IO3 =(x, x, x, x, D7, D3,...)

## 6. Quad Page Program Data

IO0 = (D4, D0, .....)

IO1 = (D5, D1, .....)

IO2 = (D6, D2, .....)

IO3 = (D7, D3,.....)

## 7. Dummy bits and Wrap Bits

IO0 = (x, x, x, x, x, x, W4, x)

IO1 = (x, x, x, x, x, x, W5, x)

IO2 = (x, x, x, x, x, x, W6, x)

IO3 = (x, x, x, x, x, x, x, x)

## 9.2 Manufacturer and Device Identification

	Command	M7-M0	ID15-ID8	ID7-ID0
GT25Q40D	9FH	C4h	40	13
	90H	C4h		12
	ABH			12
GT25Q20D	9FH	C4h	40	12
	90H	C4h		11
	ABH			11
GT25Q10D	9FH	C4h	40	11
	90H	C4h		10
	ABH			10
GT25Q05D	9FH	C4h	40	10
	90H	C4h		09
	ABH			09



# GT25Q40/20/10/05D

## 9.3 Write Enable (WREN) (06h)

The Write Enable (WREN) command is for setting the Write Enable Latch (WEL) bit. The Write Enable Latch (WEL) bit must be set prior to every Page Program (PP), Sector Erase (SE), Block Erase (BE), Chip Erase (CE), Write Status Register (WRSR) and Erase/Program Security Registers command. The Write Enable (WREN) command sequence: CS# goes low → sending the Write Enable command → CS# goes high.

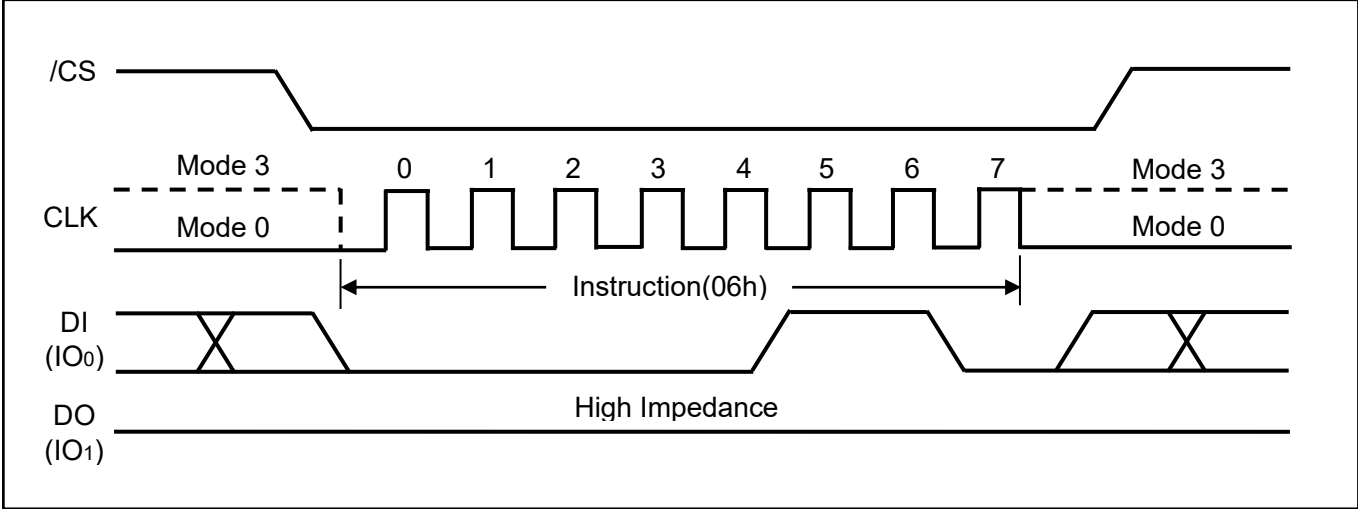

Figure1 Write Enable Sequence Diagram

## 9.4 Write Disable (WRDI) (04h)

The Write Disable command is for resetting the Write Enable Latch (WEL) bit. The Write Disable command sequence: CS# goes low → Sending the Write Disable command → CS# goes high. The WEL bit is reset by following condition: Power-up and upon completion of the Write Status Register, Page Program, Sector Erase, Block Erase, Chip Erase, Erase/Program Security Registers and Reset commands.

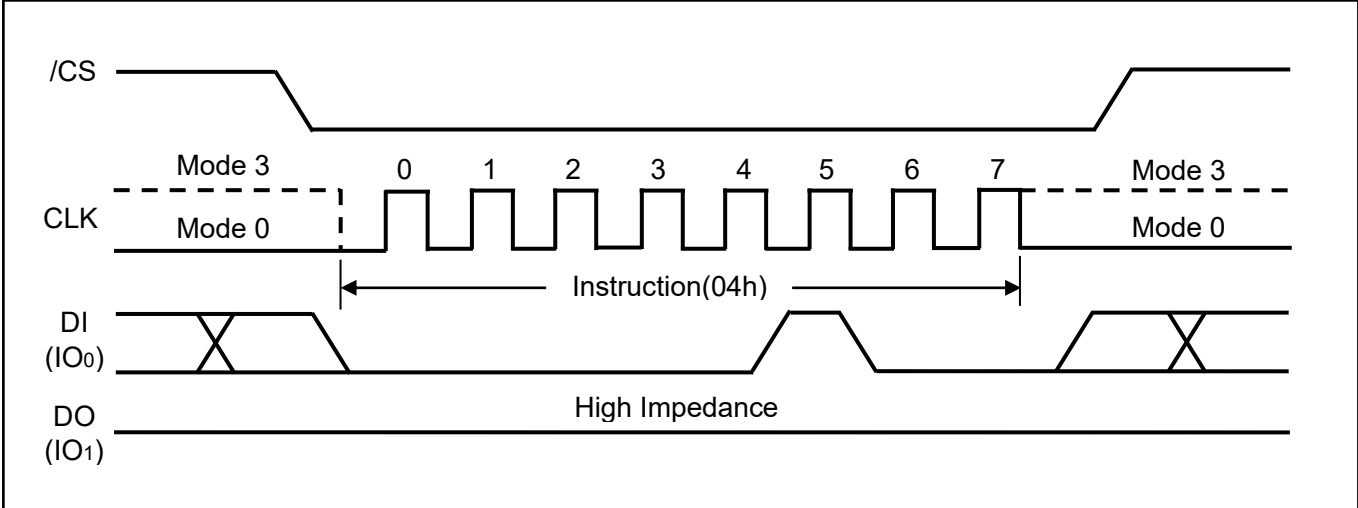

Figure2. Write Disable Sequence Diagram



# GT25Q40/20/10/05D

## 9.5 Write Enable for Volatile Status Register (50h)

The non-volatile Status Register bits can also be written to as volatile bits. This gives more flexibility to change the system configuration and memory protection schemes quickly without waiting for the typical non-volatile bit write cycles or affecting the endurance of the Status Register non-volatile bits. The Write Enable for Volatile Status Register command must be issued prior to a Write Status Register command and any other commands can't be inserted between them. Otherwise, Write Enable for Volatile Status Register will be cleared. The Write Enable for Volatile Status Register command will not set the Write Enable Latch bit, it is only valid for the Write Status Register command to change the volatile Status Register bit values.

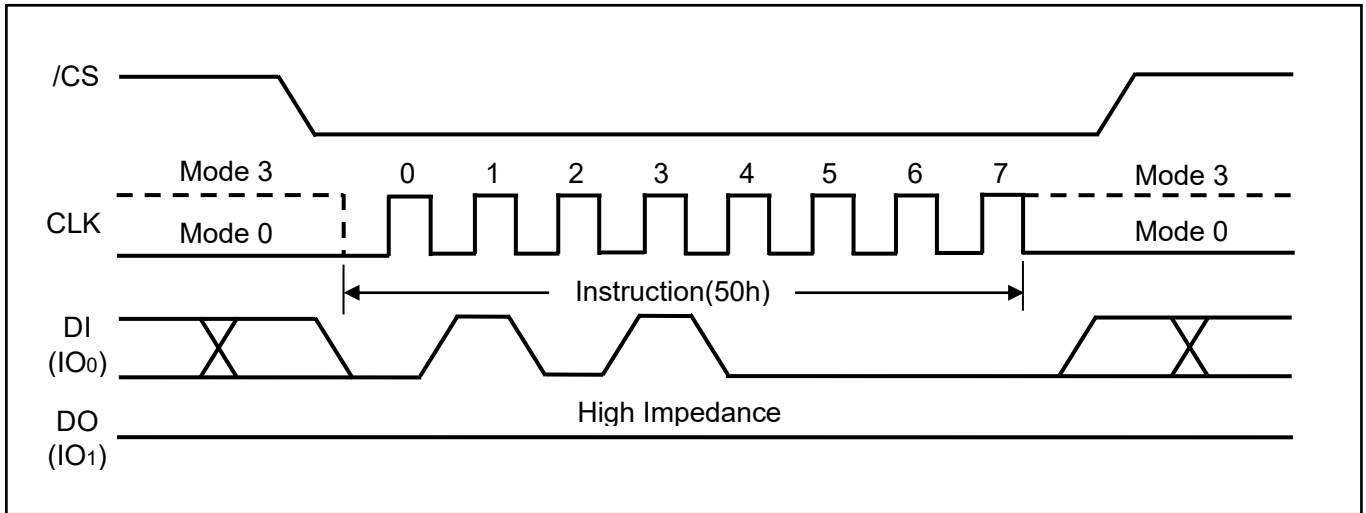
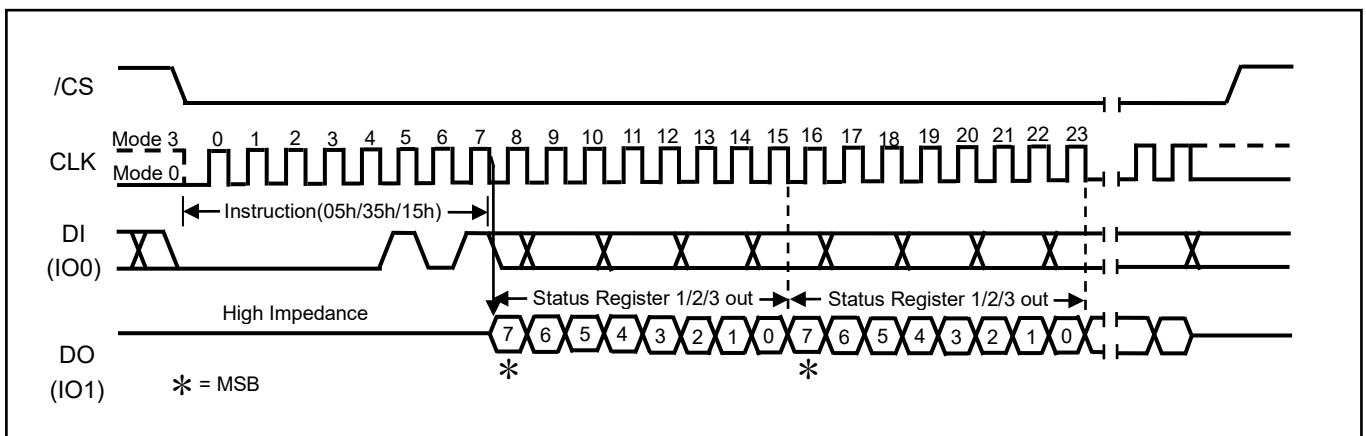

Figure3. Write Enable for Volatile Status Register Sequence Diagram

## 9.6 Read Status Register (05h/35h/15h)

The Read Status Register instructions allow the 8-bit Status Registers to be read. The instruction is entered by driving /CS low and shifting the instruction code "05h" for Status Register-1 or "35h" for Status Register-2 or "15h" for Status Register-3 into the DI pin on the rising edge of CLK. The status register bits are then shifted out on the DO pin at the falling edge of CLK with most significant bit (MSB) first as shown in figure 4. The Status Register bits are shown in Status register1 and 2 include the BUSY, WEL, BP2-BP0, TB, SEC, SRP, SRL, QE, LB, CMP, SUS, and DRV1/DRV0 bits (see Status Register section earlier in this datasheet).

The Read Status Register instruction may be used at any time, even while a Program, Erase or Write Status Register cycle is in progress. This allows the BUSY status bit to be checked to determine when the cycle is complete and if the device can accept another instruction. The Status Register can be read continuously, as shown in Figure 4. The instruction is completed by driving /CS high.





# GT25Q40/20/10/05D

Figure4. Read Status Register Sequence Diagram

## 9.7 Write Status Register (WRSR) (01h/31h/11h)

The Write Status Register instruction allows the Status Registers to be written. The writable Status Register bits include: SRP, SEC, TB, BP[2:0] in Status Register-1; CMP, LB, QE, SRP1 in Status Register-2; DRV1 and DRV0 in Status Register-3. All other Status Register bit locations are read-only and will not be affected by the Write Status Register instruction. LB are non-volatile OTP bit, once it is set to 1, it cannot be cleared to 0.

To write non-volatile Status Register bits, a standard Write Enable (06h) instruction must previously have been executed for the device to accept the Write Status Register instruction (Status Register bit WEL must equal 1). Once write enabled, the instruction is entered by driving /CS low, sending the instruction code "01h/31h/11h", and then writing the status register data byte as illustrated in Figure 5a.

To write volatile Status Register bits, a Write Enable for Volatile Status Register (50h) instruction must have been executed prior to the Write Status Register instruction (Status Register bit WEL remains 0). However, SRL and LB cannot be changed from "1" to "0" because of the OTP protection for these bits. Upon power off or the execution of a Software/Hardware Reset, the volatile Status Register bit values will be lost, and the non-volatile Status Register bit values will be restored.

During non-volatile Status Register write operation (06h combined with 01h/31h/11h, after /CS is driven high, the self-timed Write Status Register cycle will commence for a time duration of Tw (See AC Characteristics). While the Write Status Register cycle is in progress, the Read Status Register instruction may still be accessed to check the status of the BUSY bit. The BUSY bit is a 1 during the Write Status Register cycle and a 0 when the cycle is finished and ready to accept other instructions again. After the Write Status Register cycle has finished, the Write Enable Latch (WEL) bit in the Status Register will be cleared to 0.

During volatile Status Register write operation (50h combined with 01h/31h/11h), after /CS is driven high, the Status Register bits will be refreshed to the new values within the time period of Tshsl2 (See AC Characteristics). BUSY bit will remain 0 during the Status Register bit refresh period.

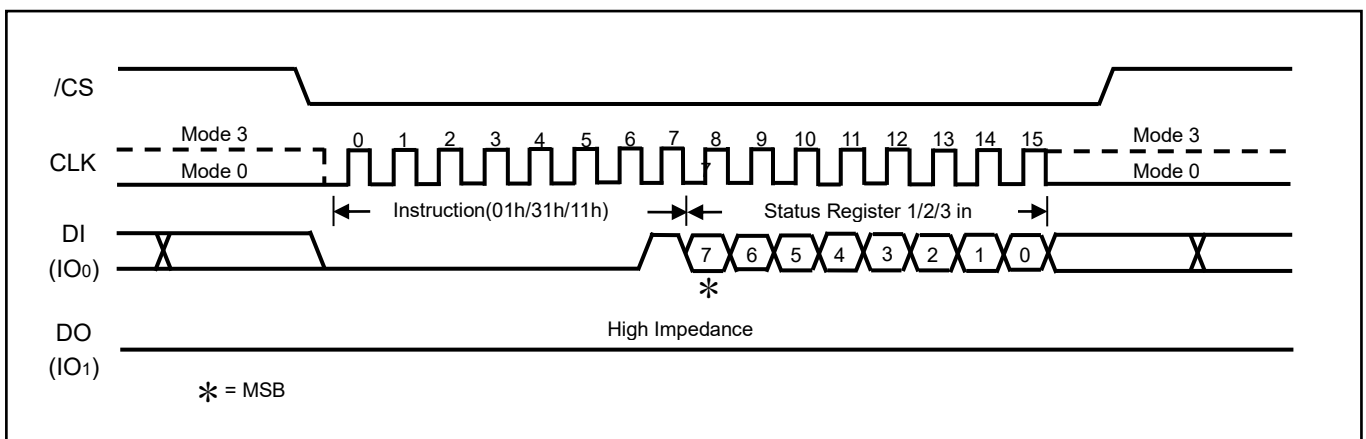

Figure5a. Write Status Register Sequence Diagram

The GT25Q40/20/10/05D is also backward compatible to Giantec's previous generations of serial flash memories, in which the Status Register-1&2 can be written using a single "Write Status Register-1 (01h)" command. To complete the Write Status Register-1&2 instruction, the /CS pin must be driven high after the sixteenth bit of data that is clocked in as shown in Figure 5b. If /CS is driven high after the eighth clock, the Write Status Register-1 (01h) instruction will only program the Status Register-1, the Status Register-2 will not be affected (Previous generations will clear CMP and QE bits).



# GT25Q40/20/10/05D

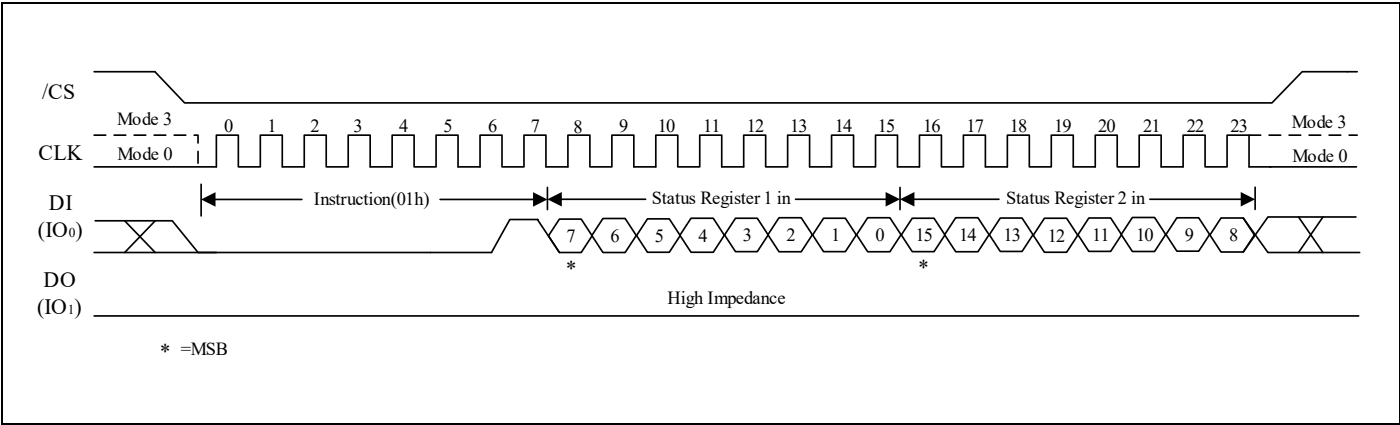

Figure 5b. Write Status Register Sequence Diagram

## 9.8 Read Data Bytes (READ) (03h)

The Read Data Bytes (READ) command is followed by a 3-byte address (A23-A0), and each bit is latched-in on the rising edge of CLK. Then the memory content, at that address, is shifted out on DO, and each bit is shifted out, at a Max frequency  $F_r$ , on the falling edge of CLK. The first byte addressed can be at any location. The address is automatically incremented to the next higher address after each byte of data is shifted out. The whole memory can, therefore, be read with a single Read Data Bytes (READ) command. Any Read Data Bytes (READ) command, while an Erase, Program or Write cycle is in progress, is rejected without having any effects on the cycle that is in progress.

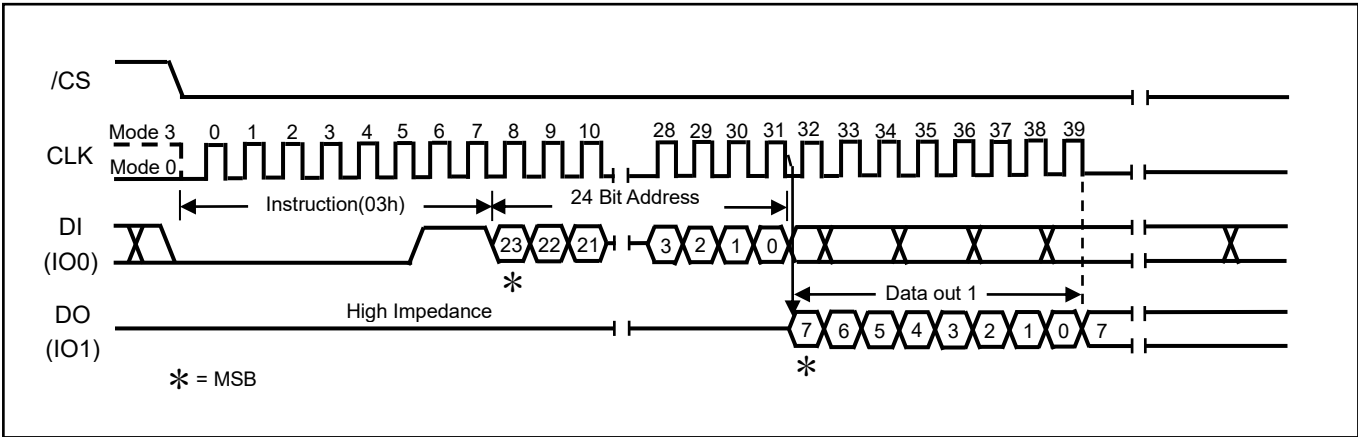

Figure 6. Read Data Bytes Sequence Diagram



# GT25Q40/20/10/05D

## 9.9 Fast Read (0Bh)

The Read Data Bytes at Higher Speed (Fast Read) command is for quickly reading data out. It is followed by a 3-byte address (A23-A0) and a dummy byte, and each bit is latched-in on the rising edge of CLK. Then the memory content, at that address, is shifted out on DO, and each bit is shifted out, at a Max frequency  $F_c$ , on the falling edge of CLK. The first byte addressed can be at any location. The address is automatically incremented to the next higher address after each byte of data is shifted out.

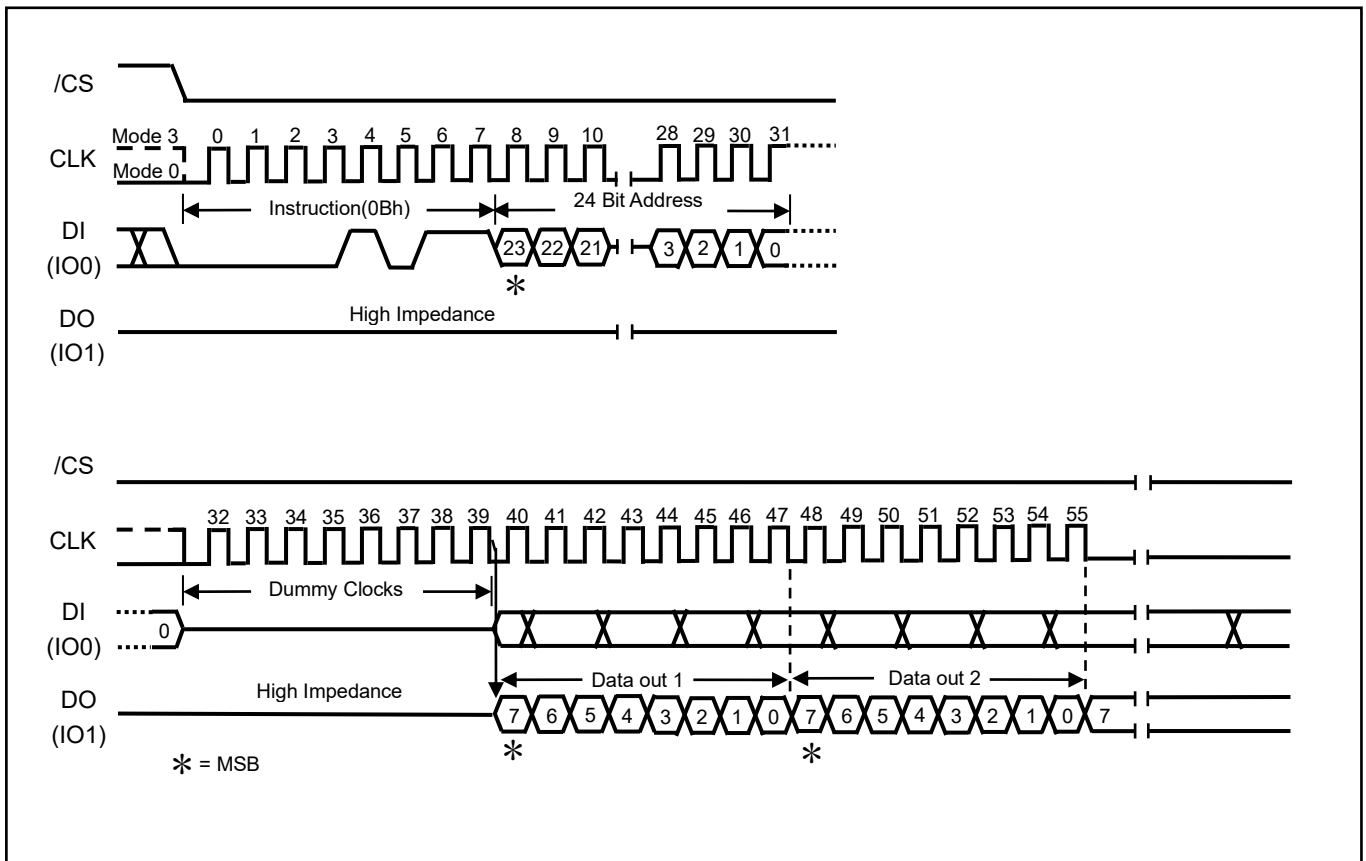

Figure7. Read Data Bytes at Higher Speed Sequence Diagram



# GT25Q40/20/10/05D

## 9.10 Dual Output Fast Read (3Bh)

The Dual Output Fast Read command is followed by 3-byte address (A23-A0) and a dummy byte, and each bit is latched in on the rising edge of CLK, then the memory contents are shifted out 2-bit per clock cycle from DI and DO. The command sequence is shown in followed Figure8. The first byte addressed can be at any location. The address is automatically incremented to the next higher address after each byte of data is shifted out.

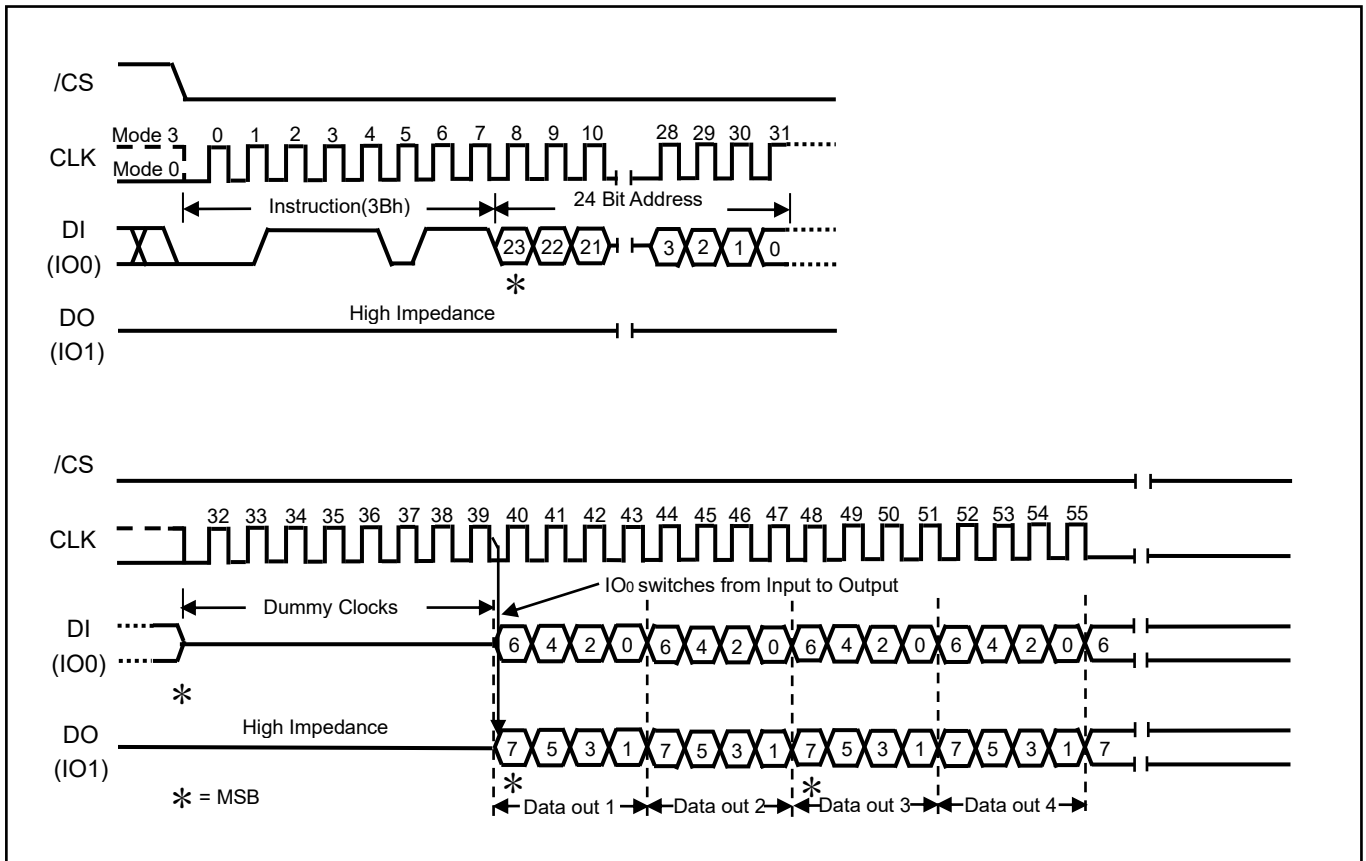

Figure8. Dual Output Fast Read Sequence Diagram



# GT25Q40/20/10/05D

## 9.11 Quad Output Fast Read (6Bh)

The Quad Output Fast Read command is followed by 3-byte address (A23-A0) and a dummy byte, and each bit is latched in on the rising edge of CLK, then the memory contents are shifted out 4-bit per clock cycle from IO3, IO2, IO1 and IO0. The command sequence is shown in followed Figure9. The first byte addressed can be at any location. The address is automatically incremented to the next higher address after each byte of data is shifted out. The Quad Enable bit (QE) of Status Register (S9) must be set to enable for the Quad Output Fast Read command.

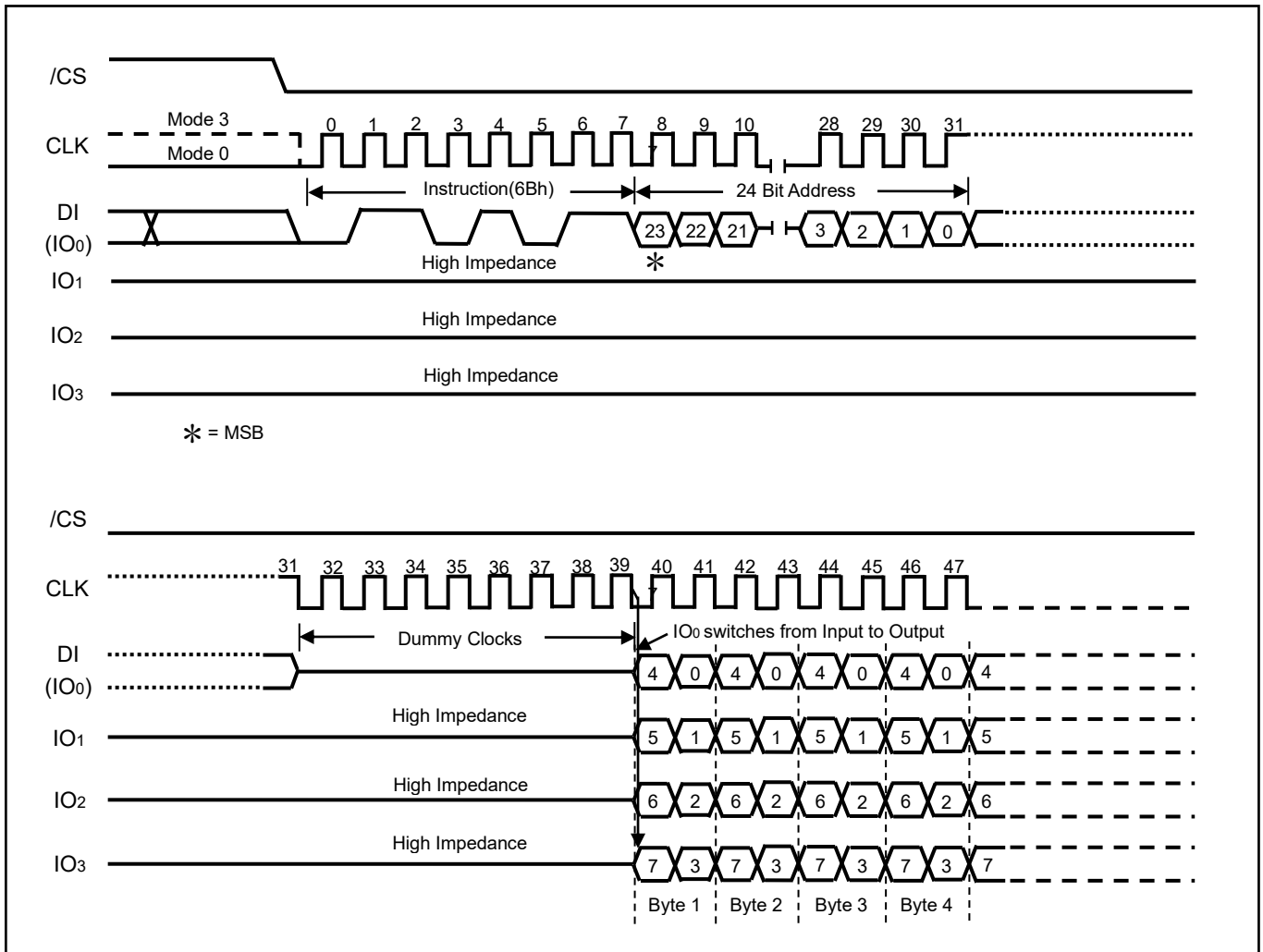

Figure9. Quad Output Fast Read Sequence Diagram



# GT25Q40/20/10/05D

## 9.12 Dual I/O Fast Read (BBH)

The Dual I/O Fast Read command is similar to the Dual Output Fast Read command but with the capability to input the 3- byte address (A23-0) and a “Continuous Read Mode” byte 2-bit per clock by DI and DO, and each bit is latched in on the rising edge of CLK, then the memory contents are shifted out 2-bit per clock cycle from DI and DO. The command sequence is shown in followed Figure10. The first byte addressed can be at any location. The address is automatically incremented to the next higher address after each byte of data is shifted out.

### Dual I/O Fast Read with “Continuous Read Mode”

The Dual I/O Fast Read command can further reduce command overhead through setting the “Continuous Read Mode” bits (M7-0) after the input 3- byte address (A23-A0). If the “Continuous Read Mode” bits (M5-4) = (1, 0), then the next Dual I/O Fast Read command (after CS# is raised and then lowered) does not require the BBH command code. The command sequence is shown in followed Figure10a. If the “Continuous Read Mode” bits (M5-4) do not equal (1, 0), the next command requires the command code, thus returning to normal operation. A “Continuous Read Mode” Reset command can be used to reset (M5-4) before issuing normal command.

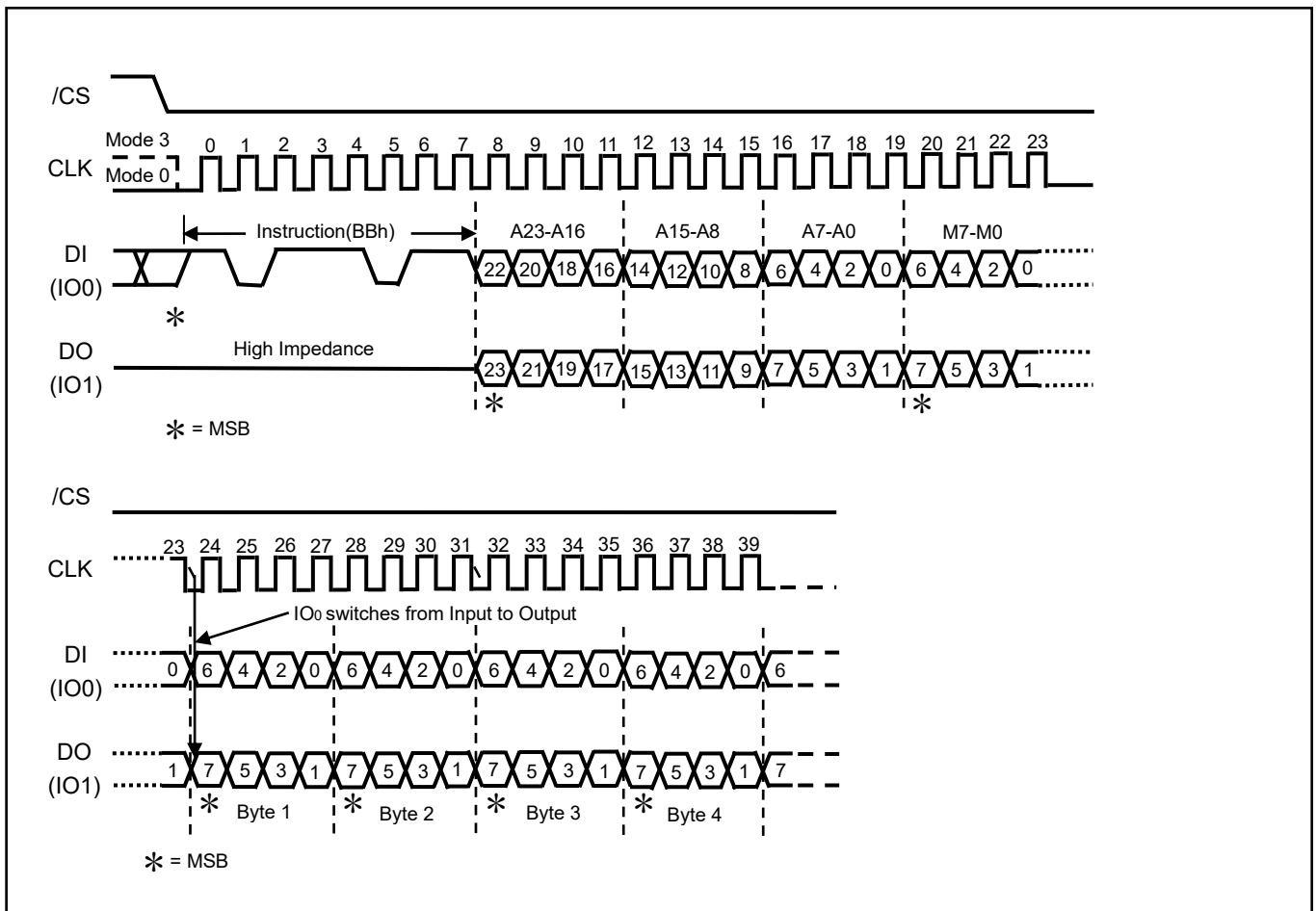

Figure10. Dual I/O Fast Read Sequence Diagram (M5-4≠(1, 0))



# GT25Q40/20/10/05D

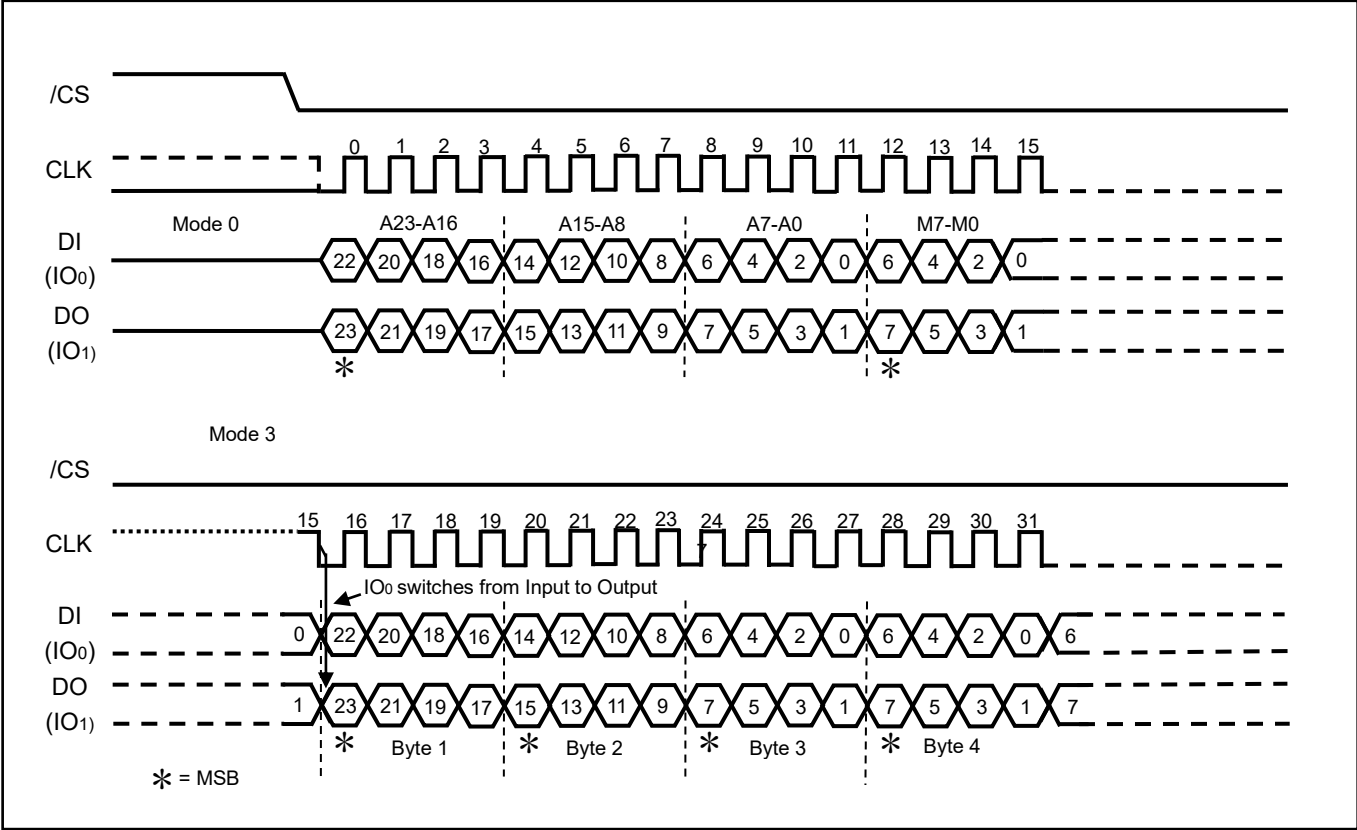

Figure10a. Dual I/O Fast Read Sequence Diagram (M5-4= (1, 0))



# GT25Q40/20/10/05D

## 9.13 Quad I/O Fast Read (EBH)

The Quad I/O Fast Read command is similar to the Dual I/O Fast Read command but with the capability to input the 3-byte address (A23-0) and a “Continuous Read Mode” byte and 4-dummy clock 4-bit per clock by IO0, IO1, IO3, IO4, and each bit is latched in on the rising edge of CLK, then the memory contents are shifted out 4-bit per clock cycle from IO0, IO1, IO2, IO3. The command sequence is shown in followed Figure11. The first byte addressed can be at any location. The address is automatically incremented to the next higher address after each byte of data is shifted out. The Quad Enable bit (QE) of Status Register (S9) must be set to enable for the Quad I/O Fast read command.

### Quad I/O Fast Read with “Continuous Read Mode”

The Quad I/O Fast Read command can further reduce command overhead through setting the “Continuous Read Mode” bits (M7-0) after the input 3-byte address (A23-A0). If the “Continuous Read Mode” bits (M5-4) = (1, 0), then the next Quad I/O Fast Read command (after CS# is raised and then lowered) does not require the EBH command code. The command sequence is shown in followed Figure11a. If the “Continuous Read Mode” bits (M5-4) do not equal to (1, 0), the next command requires the command code, thus returning to normal operation. A “Continuous Read Mode” Reset command can be used to reset (M5-4) before issuing normal command.

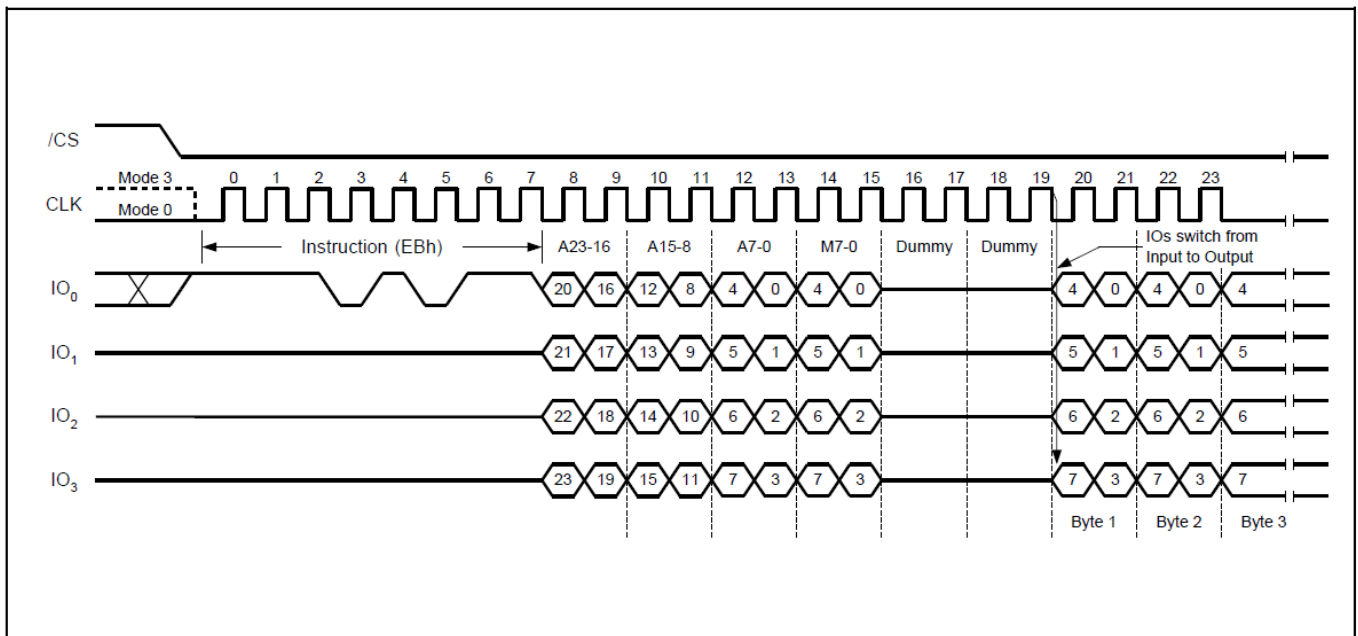

Figure11. Quad I/O Fast Read Sequence Diagram (M5-4≠(1, 0))



# GT25Q40/20/10/05D

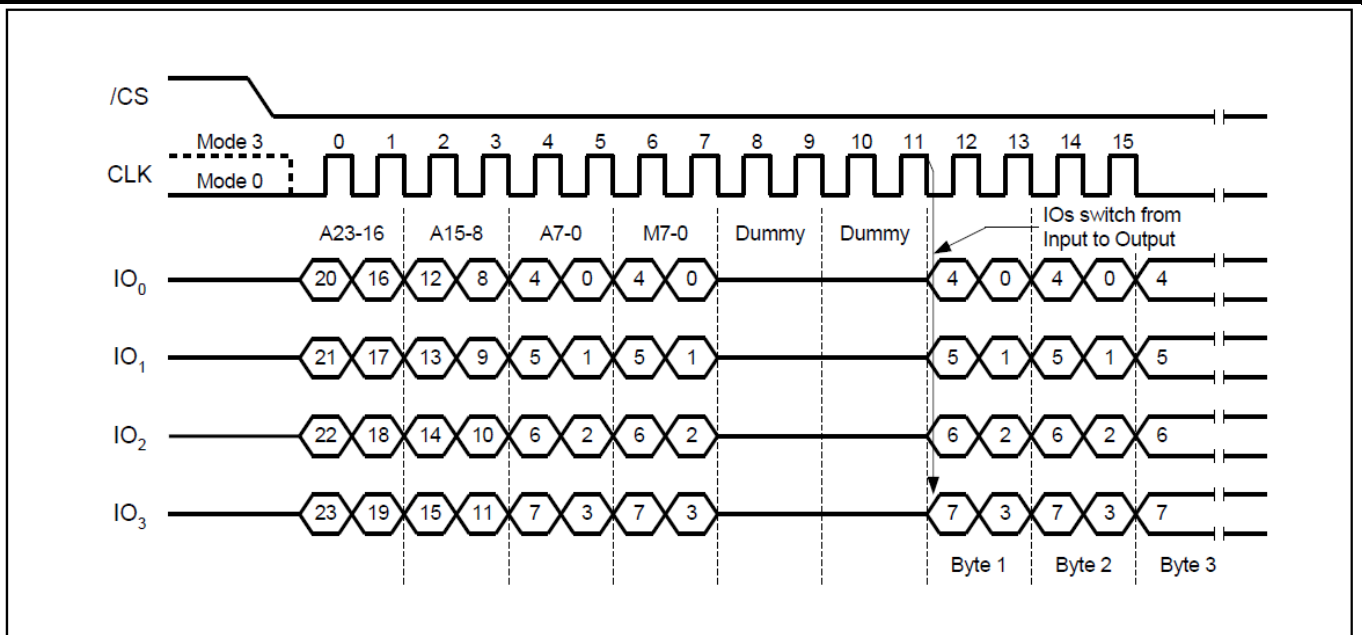

Figure 11a. Quad I/O Fast Read Sequence Diagram (M5-4= (1, 0))

## Quad I/O Fast Read with “8/16/32/64-Byte Wrap Around” in Standard SPI mode

The Quad I/O Fast Read command can be used to access a specific portion within a page by issuing “Set Burst with Wrap” (77H) command superior to EBH. The “Set Burst with Wrap” (77H) command can either enable or disable the “Wrap Around” feature for the following EBH commands. When “Wrap Around” is enabled, the data being accessed can be limited to either an 8/16/32/64-byte section of a 256-byte page. The output data starts at the initial address specified in the command, once it reaches the ending boundary of the 8/16/32/64-byte section, the output will wrap around the beginning boundary automatically until CS# is pulled high to terminate the command.

The Burst with Wrap feature allows applications that use cache to quickly fetch a critical address and then fill the cache afterwards within a fixed length (8/16/32/64-byte) of data without issuing multiple read commands. The “Set Burst with Wrap” command allows three “Wrap Bits” W6-W4 to be set. The W4 bit is used to enable or disable the “Wrap Around” operation while W6-W5 issued to specify the length of the wrap around section within a page.



# GT25Q40/20/10/05D

## 9.14 Set Burst with Wrap (77H)

The Set Burst with Wrap command is used in conjunction with “Quad I/O Fast Read” command to access a fixed length of 8/16/32/64-byte section within a 256-byte page, in standard SPI mode.

The Set Burst with Wrap command sequence: CS# goes low → Send Set Burst with Wrap command → Send 24 dummy bits → Send 8 bits “Wrap bits” → CS# goes high.

W6,W5	W4=0		W4=1 (Default)	
	Wrap Around	Wrap Length	Wrap Around	Wrap Length
0, 0	Yes	8-byte	No	N/A
0, 1	Yes	16-byte	No	N/A
1, 0	Yes	32-byte	No	N/A
1, 1	Yes	64-byte	No	N/A

If the W6-W4 bits are set by the Set Burst with Wrap command, all the following “Quad I/O Fast Read” command will use the W6-W4 setting to access the 8/16/32/64-byte section within any page. To exit the “Wrap Around” function and return to normal read operation, another Set Burst with Wrap command should be issued to set W4=1.

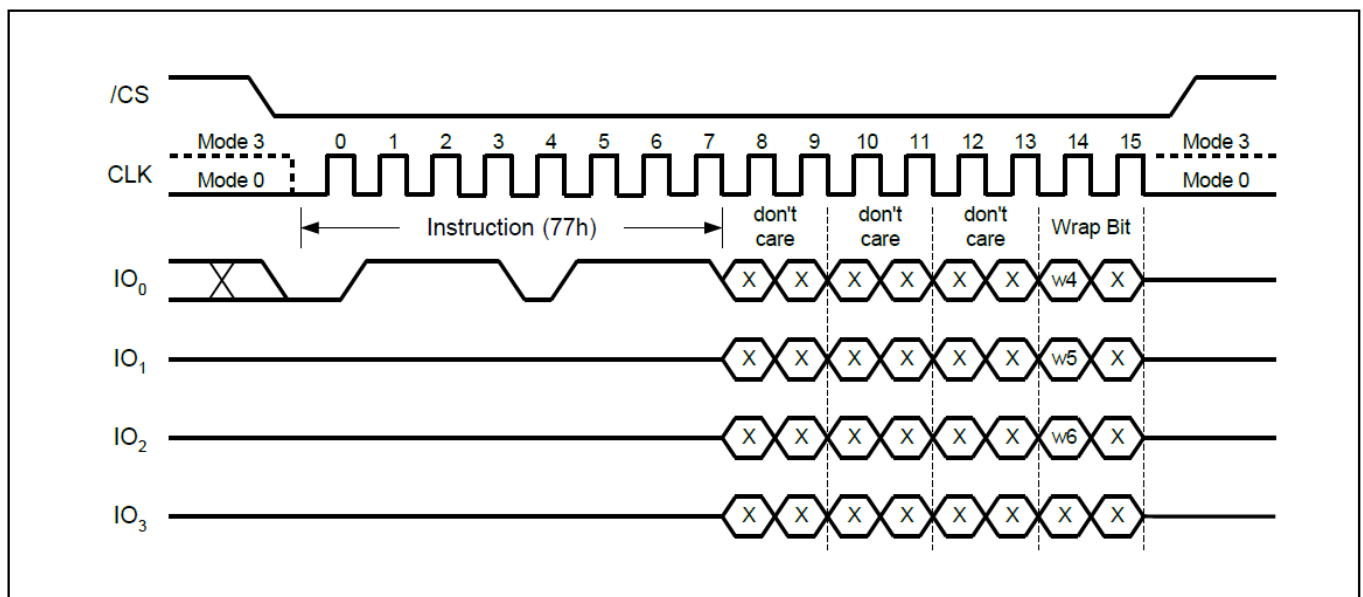

Figure12 Set Burst with Wrap Sequence Diagram



# GT25Q40/20/10/05D

## 9.15 Page Program (PP) (02H)

The Page Program (PP) command is for programming the memory. Non FFh data is programmed must be erased first, A Write Enable (WREN) command must previously have been executed to set the Write Enable Latch (WEL) bit before sending the Page Program command.

The Page Program (PP) command is entered by driving CS# Low, followed by the command code, three address bytes and at least one data byte on DI. If the 8 least significant address bits (A7-A0) are not all zero, all transmitted data that goes beyond the end of the current page are programmed from the start address of the same page (from the address whose 8 least significant bits (A7-A0) are all zero). CS# must be driven low for the entire duration of the sequence. The Page Program command sequence: CS# goes low → sending Page Program command → 3-byte address on DI → at least 1 byte data on DI → CS# goes high. The command sequence is shown in Figure13. If more than 256 bytes are sent to the device, previously latched data are discarded and the last 256 data bytes are guaranteed to be programmed correctly within the same page. If less than 256 data bytes are sent to device, they are correctly programmed at the requested addresses without having any effects on the other bytes of the same page. CS# must be driven high after the eighth bit of the last data byte has been latched in; otherwise the Page Program (PP) command is not executed.

As soon as CS# is driven high, the self-timed Page Program cycle (whose duration is  $T_{pp}$ ) is initiated. While the Page Program cycle is in progress, the Status Register may be read to check the value of the Write in Progress (BUSY) bit. The Write in Progress (BUSY) bit is 1 during the self-timed Page Program cycle, and is 0 when it is completed. At some unspecified time before the cycle is completed, the Write Enable Latch (WEL) bit is reset.

A Page Program (PP) command applied to a page which is protected by the Block Protect (CMP, SEC, TB, BP2, BP1, and BP0) is not executed.

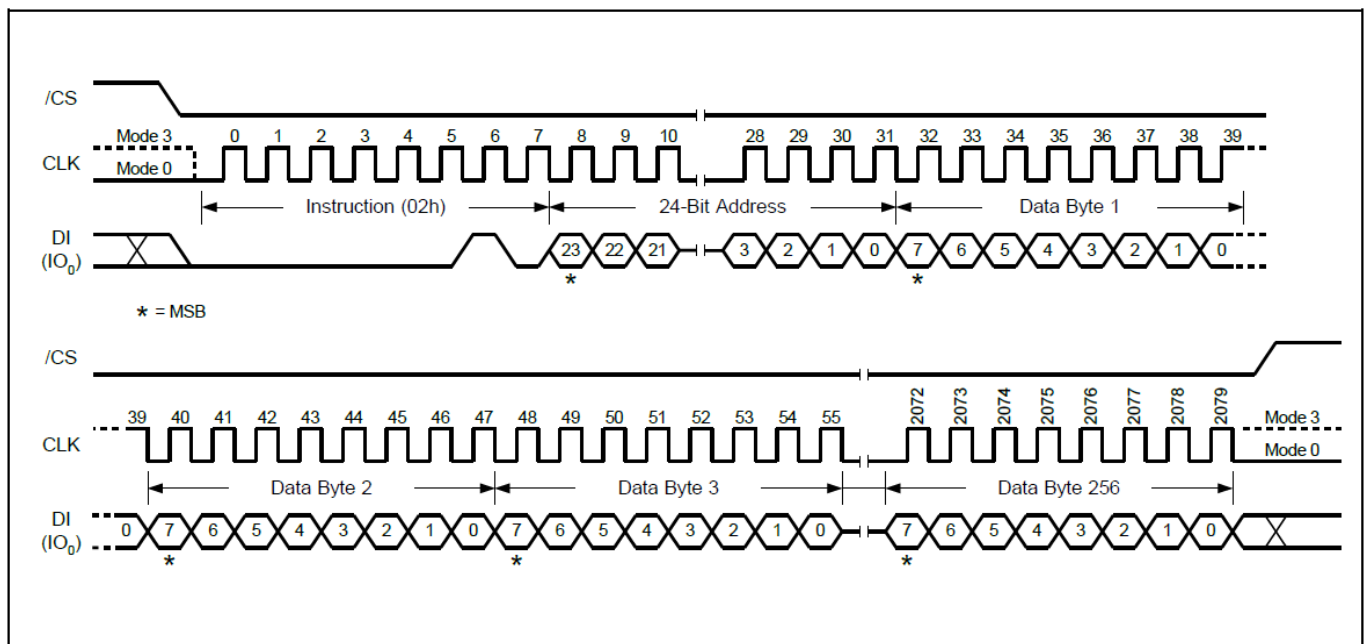

Figure13 Page Program Sequence Diagram





# GT25Q40/20/10/05D

## 9.17 Sector Erase (SE) (20H)

The Sector Erase (SE) command is for erasing the all data of the chosen 4KB sector. A Write Enable (WREN) command must previously have been executed to set the Write Enable Latch (WEL) bit. The Sector Erase (SE) command is entered by driving CS# low, followed by the command code, and 3-address byte on DI. Any address inside the sector is a valid address for the Sector Erase (SE) command. CS# must be driven low for the entire duration of the sequence.

The Sector Erase command sequence: CS# goes low → sending Sector Erase command → 3-byte address on DI → CS# goes high. The command sequence is shown in Figure15. CS# must be driven high after the eighth bit of the last address byte has been latched in; otherwise the Sector Erase (SE) command is not executed. As soon as CS# is driven high, the self-timed Sector Erase cycle (whose duration is Tse) is initiated. While the Sector Erase cycle is in progress, the Status Register may be read to check the value of the Write in Progress (BUSY) bit. The Write in Progress (BUSY) bit is 1 during the self-timed Sector Erase cycle, and is 0 when it is completed. At some unspecified time before the cycle is completed, the Write Enable Latch (WEL) bit is reset. A Sector Erase (SE) command applied to a sector which is protected by the Block Protect (CMP, SEC, TB, BP2, BP1, and BP0) bit is not executed.

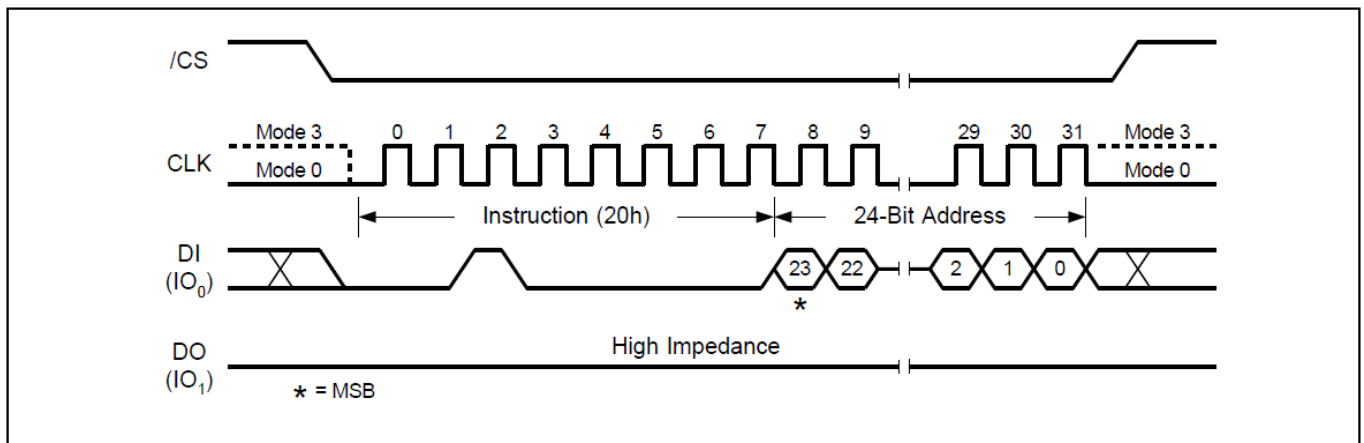

Figure15. Sector Erase Sequence Diagram



# GT25Q40/20/10/05D

## 9.18 32KB Block Erase (BE) (52H)

The 32KB Block Erase (BE) command is for erasing the all data of the chosen block. A Write Enable (WREN) command must previously have been executed to set the Write Enable Latch (WEL) bit. The 32KB Block Erase (BE) command is entered by driving CS# low, followed by the command code, and three address bytes on DI. Any address inside the block is a valid address for the 32KB Block Erase (BE) command. CS# must be driven low for the entire duration of the sequence.

The 32KB Block Erase command sequence: CS# goes low → sending 32KB Block Erase command → 3-byte address on DI → CS# goes high. The command sequence is shown in Figure16. CS# must be driven high after the eighth bit of the last address byte has been latched in; otherwise the 32KB Block Erase (BE) command is not executed. As soon as CS# is driven high, the self-timed Block Erase cycle (whose duration is Tse) is initiated. While the Block Erase cycle is in progress, the Status Register may be read to check the value of the Write in Progress (BUSY) bit. The Write in Progress (BUSY) bit is 1 during the self-timed Block Erase cycle, and is 0 when it is completed. At some unspecified time before the cycle is completed, the Write Enable Latch (WEL) bit is reset. A 32KB Block Erase (BE) command applied to a block which is protected by the Block Protect (CMP, SEC, TB, BP2, BP1, and BP0) bits (see Table 1-2) is not executed.

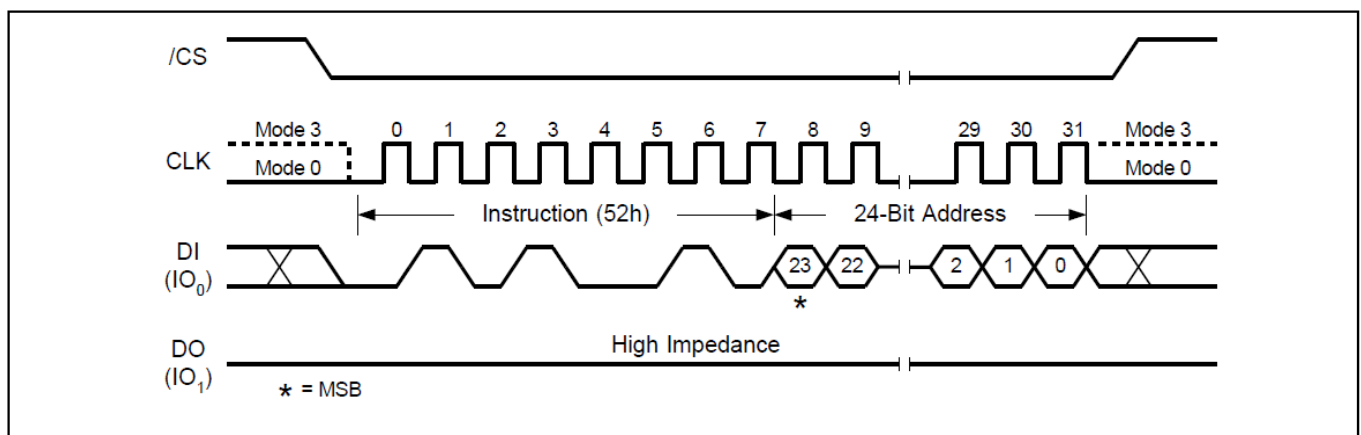

Figure16. 32KB Block Erase Sequence Diagram



# GT25Q40/20/10/05D

## 9.19 64KB Block Erase (BE) (D8H)

The 64KB Block Erase (BE) command is for erasing the all data of the chosen block. A Write Enable (WREN) command must previously have been executed to set the Write Enable Latch (WEL) bit. The 64KB Block Erase (BE) command is entered by driving CS# low, followed by the command code, and three address bytes on DI. Any address inside the block is a valid address for the 64KB Block Erase (BE) command. CS# must be driven low for the entire duration of the sequence.

The 64KB Block Erase command sequence: CS# goes low → sending 32KB Block Erase command → 3-byte address on DI → CS# goes high. The command sequence is shown in Figure 17. CS# must be driven high after the eighth bit of the last address byte has been latched in; otherwise the 64KB Block Erase (BE) command is not executed. As soon as CS# is driven high, the self-timed Block Erase cycle (whose duration is Tse) is initiated. While the Block Erase cycle is in progress, the Status Register may be read to check the value of the Write in Progress (BUSY) bit. The Write in Progress (BUSY) bit is 1 during the self-timed Block Erase cycle, and is 0 when it is completed. At some unspecified time before the cycle is completed, the Write Enable Latch (WEL) bit is reset. A 64KB Block Erase (BE) command applied to a block which is protected by the Block Protect (CMP, SEC, TB, BP2, BP1, and BP0) bits is not executed.

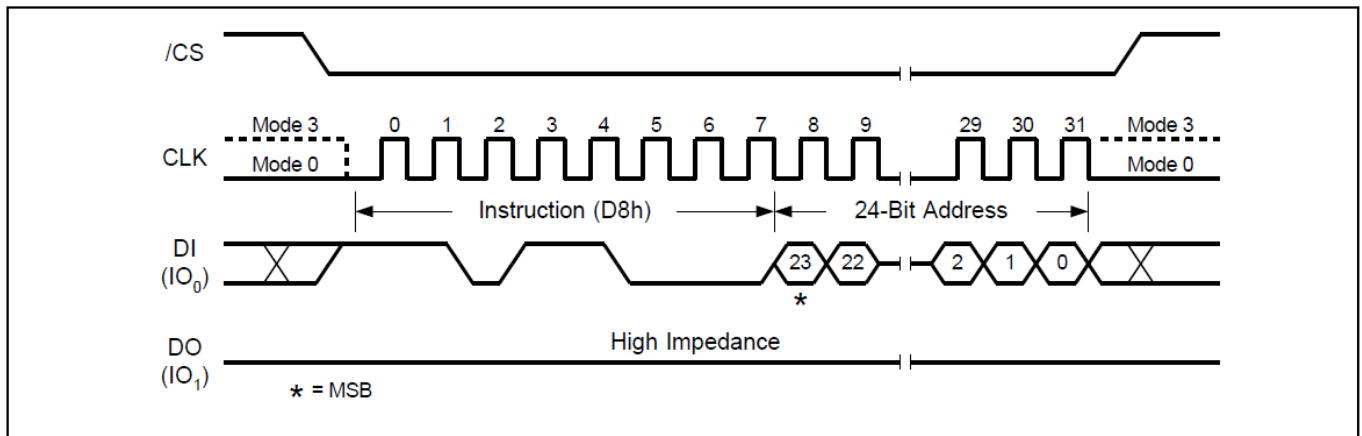

Figure17. 64KB Block Erase Sequence Diagram



# GT25Q40/20/10/05D

## 9.20 Chip Erase (CE) (60/C7H)

The Chip Erase (CE) command is for erasing the all data of the chip. A Write Enable (WREN) command must previously have been executed to set the Write Enable Latch (WEL) bit .The Chip Erase (CE) command is entered by driving CS# Low, followed by the command code on Serial Data Input (DI). CS# must be driven Low for the entire duration of the sequence.

The Chip Erase command sequence: CS# goes low → sending Chip Erase command → CS# goes high. The command sequence is shown in Figure18. CS# must be driven high after the eighth bit of the command code has been latched in; otherwise the Chip Erase command is not executed. As soon as CS# is driven high, the self-timed Chip Erase cycle (whose duration is Tce) is initiated. While the Chip Erase cycle is in progress, the Status Register may be read to check the value of the Write in Progress (BUSY) bit. The Write in Progress (BUSY) bit is 1 during the self-timed Chip Erase cycle, and is 0 when it is completed. At some unspecified time before the cycle is completed, the Write Enable Latch (WEL) bit is reset. The Chip Erase (CE) command is executed, if the Block Protect (BP2, BP1, and BP0) bits are 0 and CMP=0 or the Block Protect (BP2, BP1, and BP0) bits are 1 and CMP=1.

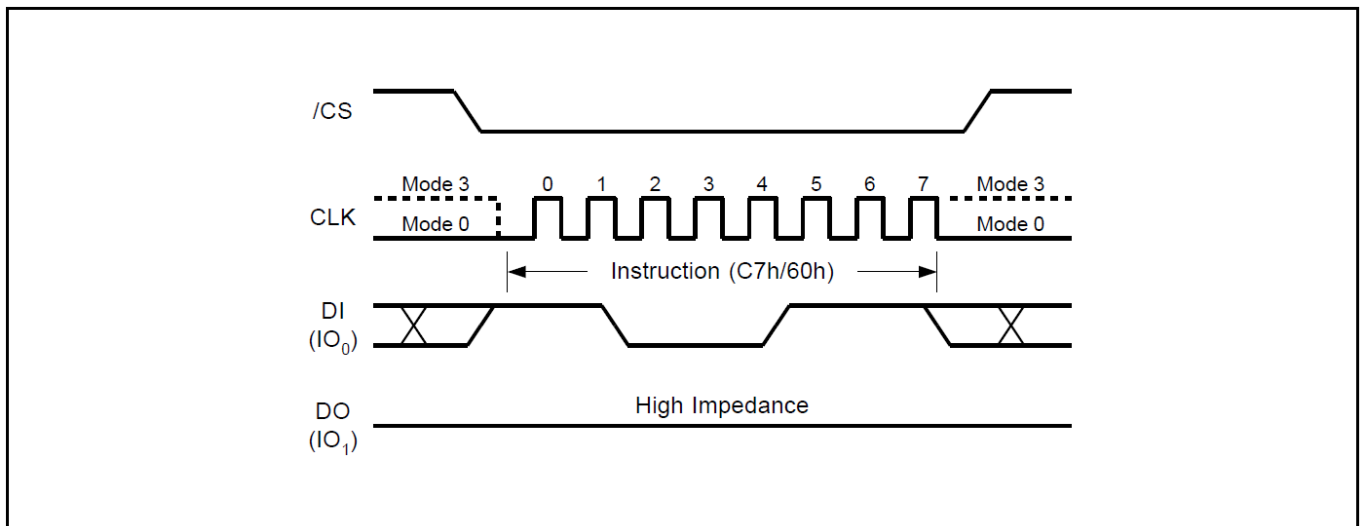

Figure18. Chip Erase Sequence Diagram



# GT25Q40/20/10/05D

## 9.21 Deep Power-Down (DP) (B9H)

Executing the Deep Power-Down (DP) command is the only way to put the device in the lowest consumption mode (the Deep Power-Down Mode). It can also be used as an extra software protection mechanism, while the device is not in active use, since in this mode, the device ignores all Write, Program and Erase commands. Driving CS# high deselects the device, and puts the device in the Standby Mode (if there is no internal cycle currently in progress). But this mode is not the Deep Power-Down Mode. The Deep Power-Down Mode can only be entered by executing the Deep Power-Down (DP) command. Once the device has entered the Deep Power-Down Mode, all commands are ignored except the Release from Deep Power-Down and Read Device ID (RDI) command or software reset command. The Release from Deep Power-Down and Read Device ID (RDI) command releases the device from Deep Power-Down mode, also allows the Device ID of the device to be output on DO.

The Deep Power-Down Mode automatically stops at Power-Down, and the device always in the Standby Mode after Power-Up. The Deep Power-Down command sequence: CS# goes low → sending Deep Power-Down command → CS# goes high. The command sequence is shown in Figure19. CS# must be driven high after the eighth bit of the command code has been latched in; otherwise the Deep Power-Down (DP) command is not executed. As soon as CS# is driven high, it requires a delay of  $t_{DP}$  before the supply current is reduced to IDPD and the Deep Power-Down Mode is entered. Any Deep Power-Down (DP) command, while an Erase, Program or Write cycle is in progress, is rejected without having any effects on the cycle that is in progress.

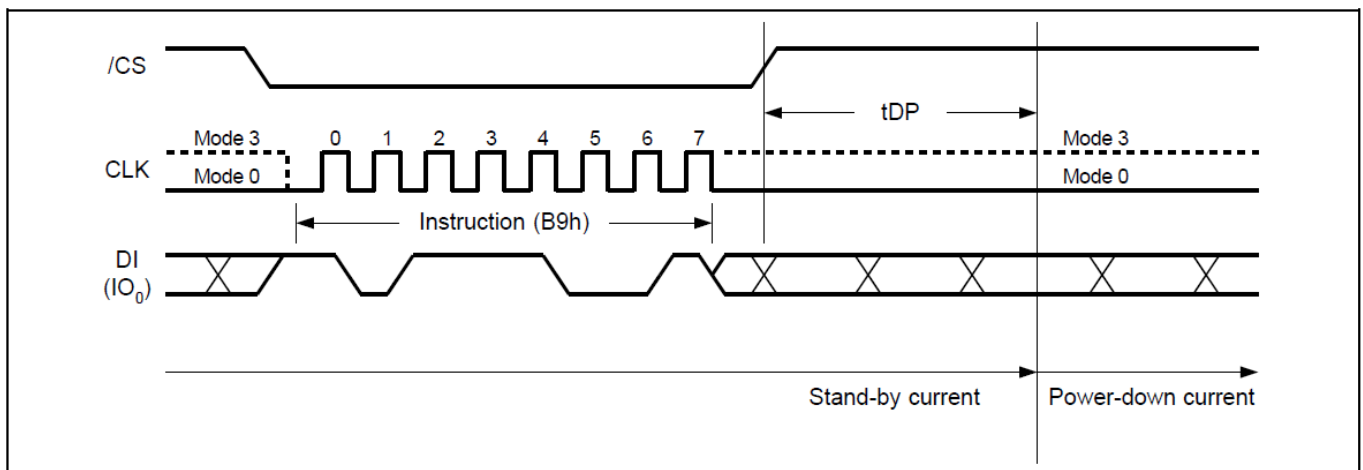

Figure19. Deep Power-Down Sequence Diagram



# GT25Q40/20/10/05D

## 9.22 Release from Deep Power-Down and Read Device ID (RDI) (ABH)

The Release from Power-Down and Read Device ID command is a multi-purpose command. It can be used to release the device from the Power-Down state or obtain the devices electronic identification (ID) number.

To release the device from the Power-Down state, the command is issued by driving the CS# pin low, shifting the instruction code “ABH” and driving CS# high as shown in Figure20. Release from Power-Down will take the time duration of  $t_{RES1}$  (See AC Characteristics) before the device will resume normal operation and other command are accepted. The CS# pin must remain high during the  $t_{RES1}$  time duration.

When used only to obtain the Device ID while not in the Power-Down state, the command is initiated by driving the CS# pin low and shifting the instruction code “ABH” followed by 3-dummy byte. The Device ID bits are then shifted out on the falling edge of CLK with most significant bit (MSB) first as shown in Figure21. The Device ID value is listed in Manufacturer and Device Identification table. The Device ID can be read continuously. The command is completed by driving CS# high.

When used to release the device from the Power-Down state and obtain the Device ID, the command is the same as previously described, and shown in Figure21, except that after CS# is driven high it must remain high for a time duration of  $t_{RES2}$  (See AC Characteristics). After this time duration the device will resume normal operation and other command will be accepted. If the Release from Power-Down and Read Device ID command is issued while an Erase, Program or Write cycle is in process (when BUSY equal 1) the command is ignored and will not have any effects on the current cycle.

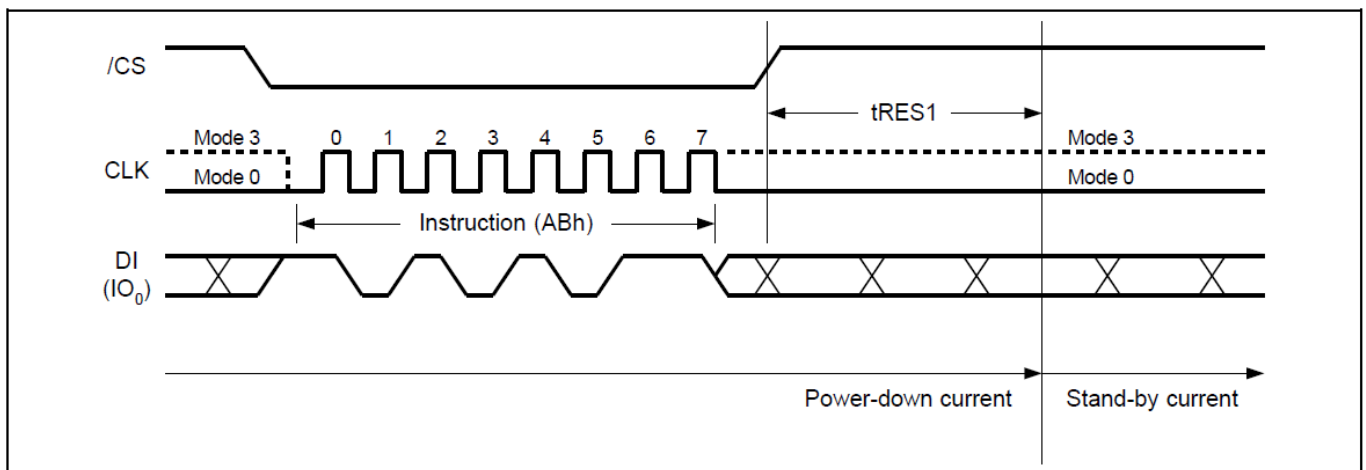

Figure20. Release Power-Down Sequence Diagram

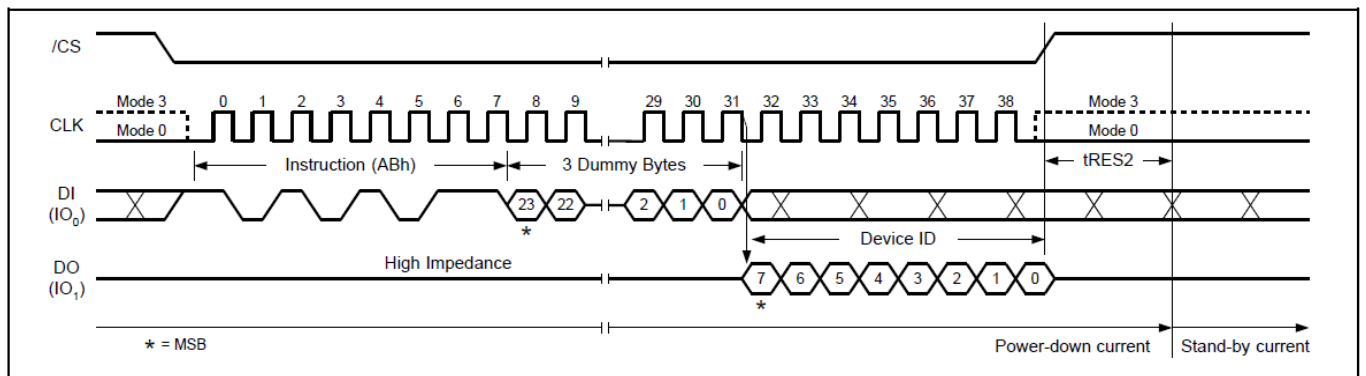

Figure21. Release Power-Down/Read Device ID Sequence Diagram



# GT25Q40/20/10/05D

## 9.23 Read Manufacture ID/ Device ID (REMS) (90H)

The Read Manufacturer/Device ID command is an alternative to the Release from Power-Down / Device ID command that provides both the JEDEC assigned Manufacturer ID and the specific Device ID.

The command is initiated by driving the CS# pin low and shifting the command code “90H” followed by a 24-bit address (A23-A0) of 000000H. After which, the Manufacturer ID and the Device ID are shifted out on the falling edge of CLK with most significant bit (MSB) first as shown in Figure22. If the 24-bit address is initially set to 000001H, the Device ID will be read first.

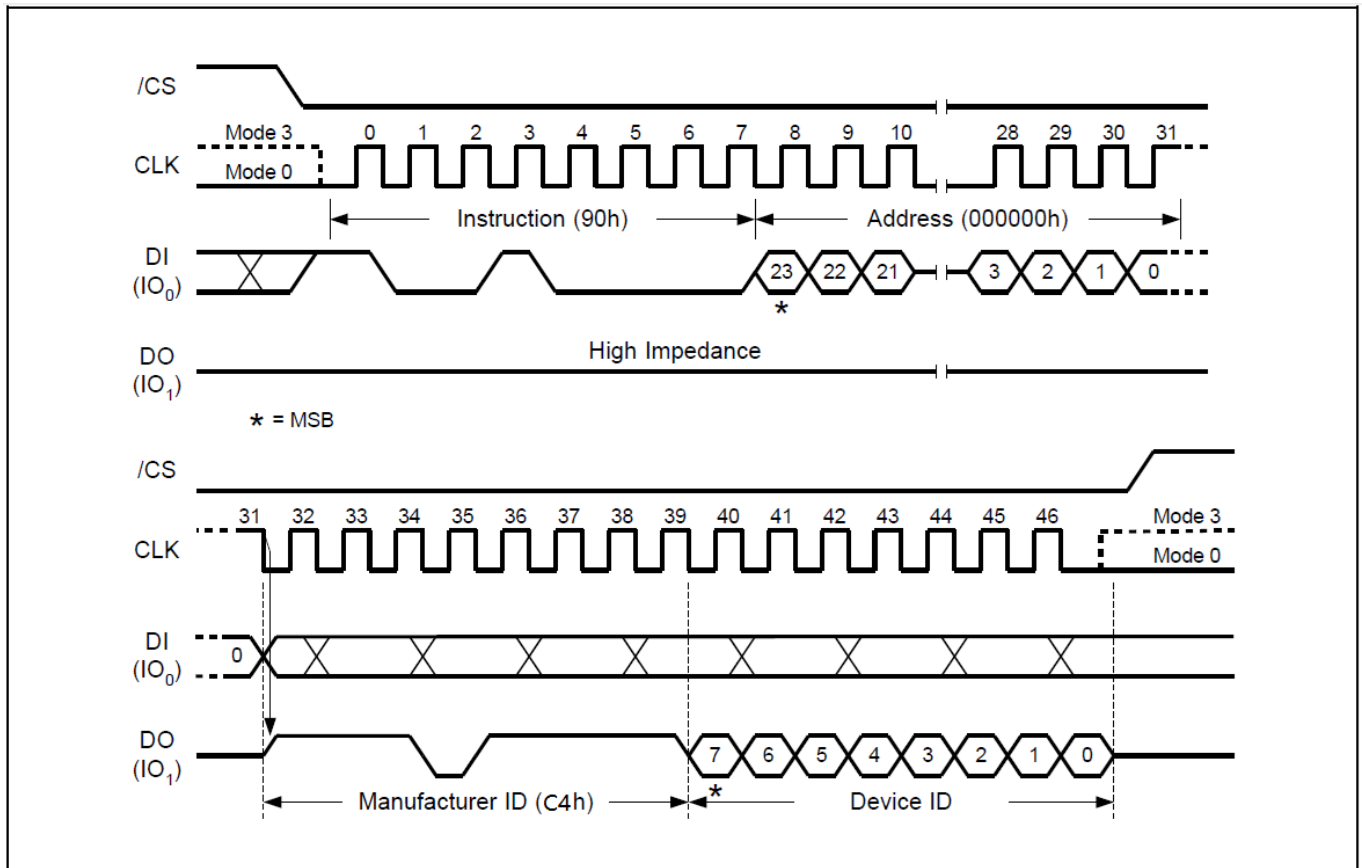

Figure22 Read Manufacture ID/ Device ID Sequence Diagram



# GT25Q40/20/10/05D

## 9.24 Read Manufacture ID/ Device ID Dual I/O (92H)

The Read Manufacturer/Device ID Dual I/O command is an alternative to the Release from Power-Down / Device ID command that provides both the JEDEC assigned Manufacturer ID and the specific Device ID by dual I/O.

The command is initiated by driving the CS# pin low and shifting the command code "92H" followed by a 24-bit address (A23-A0) of 000000H. After which, the Manufacturer ID and the Device ID are shifted out on the falling edge of CLK with most significant bit (MSB) first as shown in Figure23. If the 24-bit address is initially set to 000001H, the Device ID will be read first.

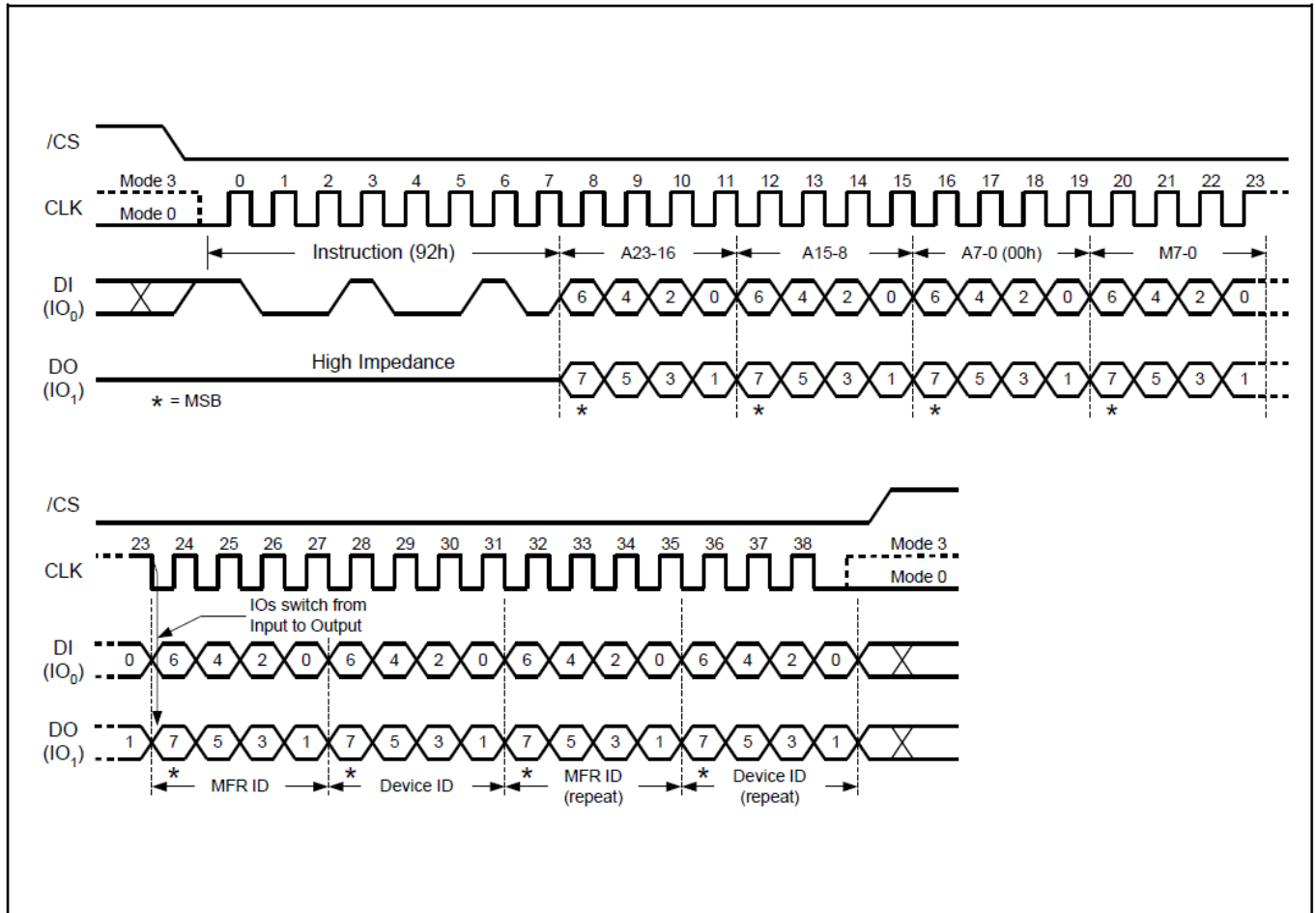

Figure23. Read Manufacture ID/ Device ID Dual I/O Sequence Diagram



# GT25Q40/20/10/05D

## 9.25 Read Manufacture ID/ Device ID Quad I/O (94H)

The Read Manufacturer/Device ID Quad I/O command is an alternative to the Release from Power-Down / Device ID command that provides both the JEDEC assigned Manufacturer ID and the specific Device ID by quad I/O.

The command is initiated by driving the CS# pin low and shifting the command code “94H” followed by a 24-bit address (A23-A0) of 000000H. After which, the Manufacturer ID and the Device ID are shifted out on the falling edge of CLK with most significant bit (MSB) first as shown in Figure24. If the 24-bit address is initially set to 000001H, the Device ID will be read first.

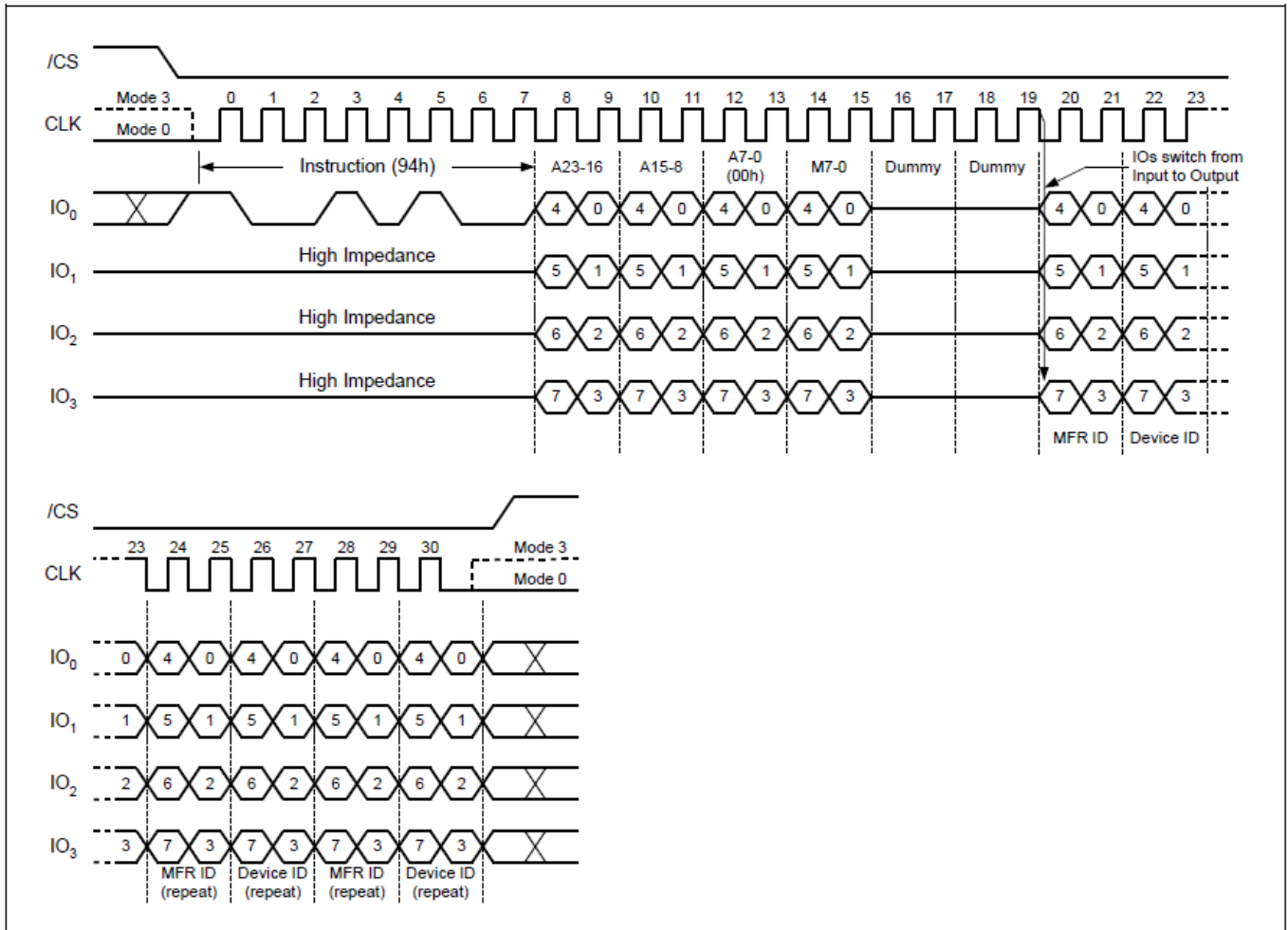

Figure24. Read Manufacture ID/ Device ID Quad I/O Sequence Diagram



# GT25Q40/20/10/05D

## 9.26 Read Identification (RDID) (9Fh)

The Read Identification (RDID) command allows the 8-bit manufacturer identification to be read, followed by two bytes of device identification. The device identification indicates the memory type in the first byte, and the memory capacity of the device in the second byte. The Read Identification (RDID) command while an Erase or Program cycle is in progress, is not decoded, and has no effect on the cycle that is in progress. The Read Identification (RDID) command should not be issued while the device is in Deep Power-Down Mode.

The device is first selected by driving CS# low. Then, the 8-bit command code for the command is shifted in. This is followed by the 24-bit device identification, stored in the memory. Each bit is shifted out on the falling edge of Serial Clock. The command sequence is shown in Figure 25. The Read Identification (RDID) command is terminated by driving CS# high at any time during data output. When CS# is driven high, the device is in the Standby Mode. Once in the Standby Mode, the device waits to be selected, so that it can receive, decode and execute commands.

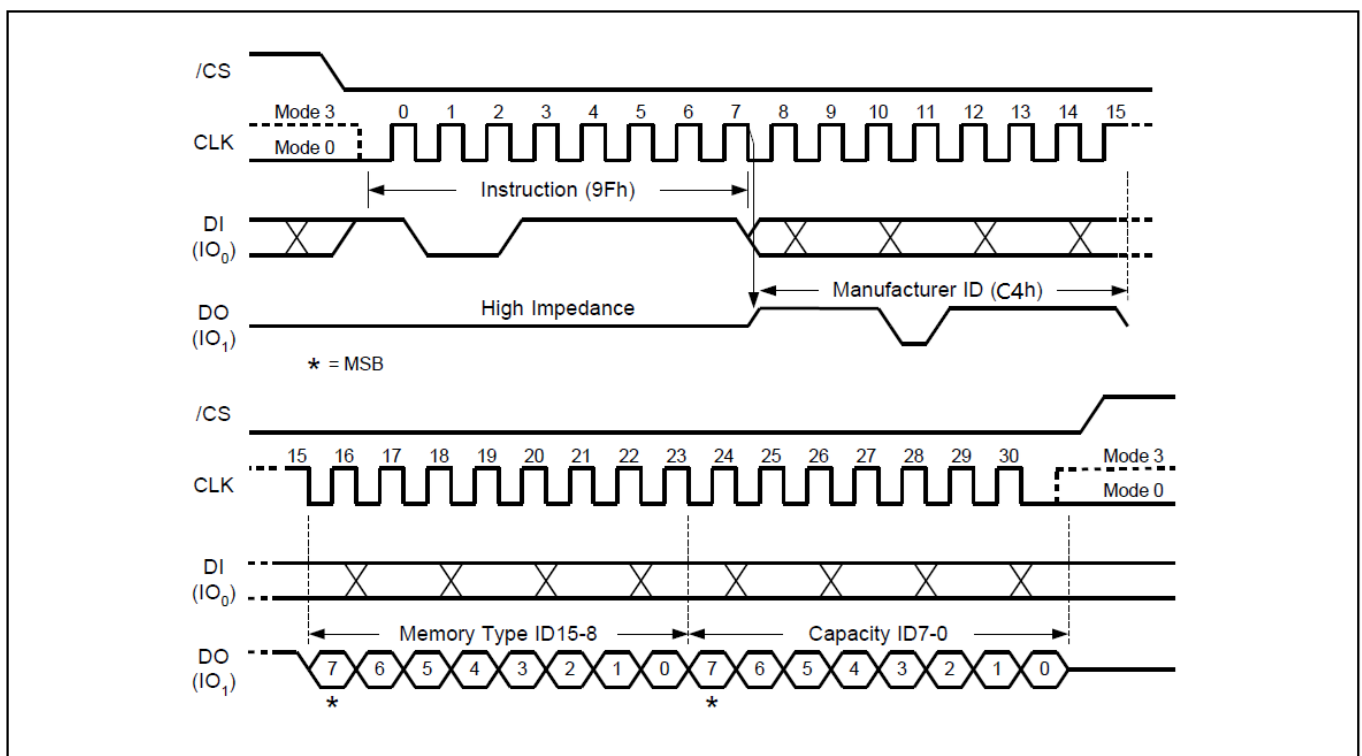

Figure25.Read Identification ID Sequence Diagram



# GT25Q40/20/10/05D

## 9.27 Read Unique ID Number (4Bh)

The Read Unique ID Number instruction accesses a factory-set read-only 64-bit number that is unique to each GT25Q40/20/10/05D device. The ID number can be used in conjunction with user software methods to help prevent copying or cloning of a system. The Read Unique ID instruction is initiated by driving the /CS pin low and shifting the instruction code “4Bh” followed by a four bytes of dummy clocks. After which, the 64-bit ID is shifted out on the falling edge of CLK as shown in figure 26.

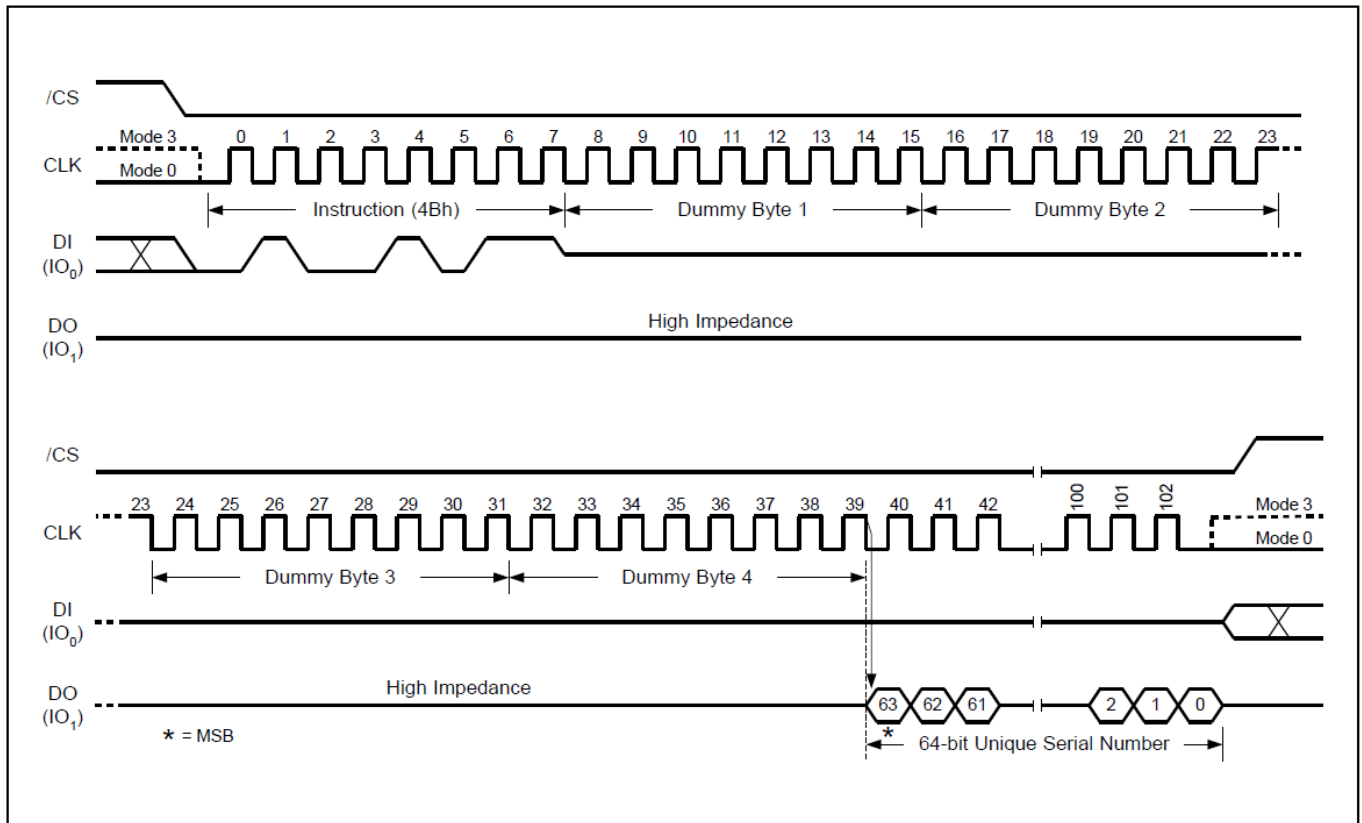

Figure26. Read Unique ID Number Instruction Sequence



# GT25Q40/20/10/05D

## 9.28 Program/Erase Suspend (PES) (75H)

The Erase/Program Suspend instruction “75H”, allows the system to interrupt a Sector or Block Erase operation or a Page Program operation and then read from or program/erase data to, any other sectors or blocks. The Erase/Program Suspend instruction sequence is shown in Figure27.

The Write Status Register instruction (01h) and Erase instructions (82h, 20h, 52h, D8h, C7h, 60h, 44h) are not allowed during Erase Suspend. Erase Suspend is valid only during the Sector or Block erase operation. If written during the Chip Erase operation, the Erase Suspend instruction is ignored. The Write Status Register instruction (01h) and Program instructions (02h, 32h, 42h) are not allowed during Program Suspend. Program Suspend is valid only during the Page Program or Quad Page Program operation.

The Erase/Program Suspend instruction “75H” will be accepted by the device only if the SUS bit in the Status Register equals to 0 and the BUSY bit equals to 1 while a Sector or Block Erase or a Page Program operation is on-going. If the SUS bit equals to 1 or the BUSY bit equals to 0, the Suspend instruction will be ignored by the device. A maximum of time of “Tsus” (See AC Characteristics) is required to suspend the erase or program operation. The BUSY bit in the Status Register will be cleared from 1 to 0 within “Tsus” and the SUS bit in the Status Register will be set from 0 to 1 immediately after Erase/Program Suspend. For a previously resumed Erase/Program operation, it is also required that the Suspend instruction “75H” is not issued earlier than a minimum of time of “Tsus” following the preceding Resume instruction “7AH”.

Unexpected power off during the Erase/Program suspend state will reset the device and release the suspend state. SUS bit in the Status Register will also reset to 0. The data within the page, sector or block that was being suspended may become corrupted. It is recommended for the user to implement system design techniques against the accidental power interruption and preserve data integrity during erase/program suspend state.

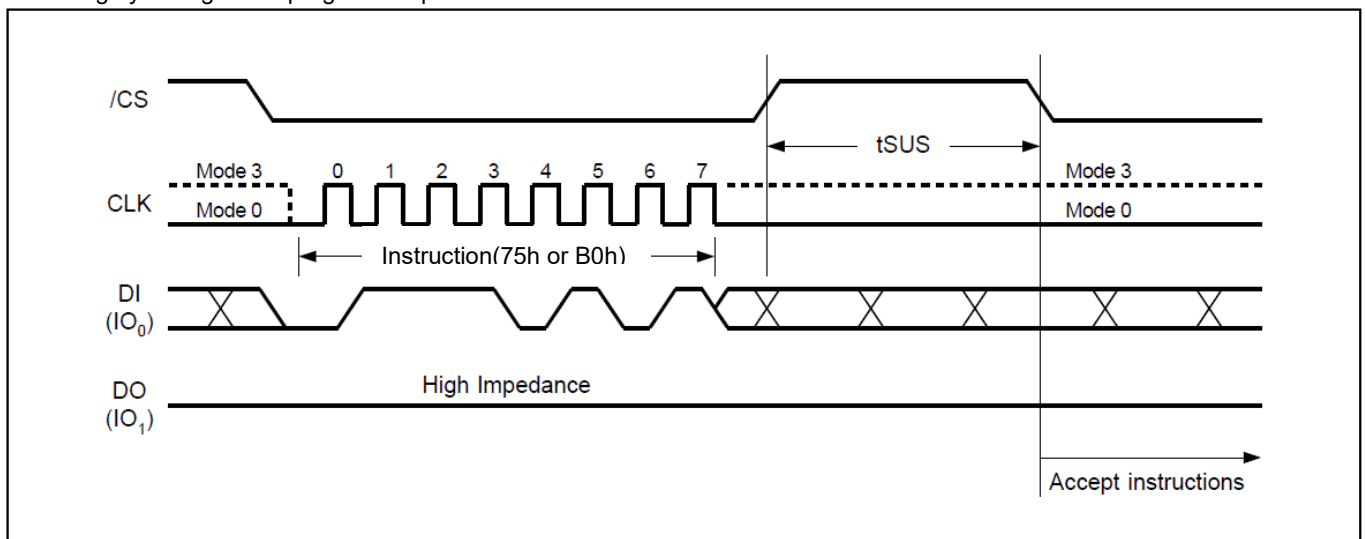

Figure27. Program/Erase Suspend Sequence Diagram

Note:

1, If it is 1byte program or 2byte program, the suspend command must be sent after 30us after CS pulling up



# GT25Q40/20/10/05D

## 9.29 Program/Erase Resume (PER) (7AH)

The Erase/Program Resume instruction “7AH” must be written to resume the Sector or Block Erase operation or the Page Program operation after an Erase/Program Suspend. The Resume instruction “7AH” will be accepted by the device only if the SUS bit in the Status Register equals to 1 and the BUSY bit equals to 0. After issued the SUS bit will be cleared from 1 to 0 immediately, the BUSY bit will be set from 0 to 1 within 200ns and the Sector or Block will complete the erase operation or the page will complete the program operation. If the SUS bit equals to 0 or the BUSY bit equals to 1, the Resume instruction “7AH” will be ignored by the device. The Erase/Program Resume instruction sequence is shown in Figure28.

Resume instruction is ignored if the previous Erase/Program Suspend operation was interrupted by unexpected power off. It is also required that a subsequent Erase/Program Suspend instruction not to be issued within a minimum of time of “T<sub>sus</sub>” following a previous Resume instruction.

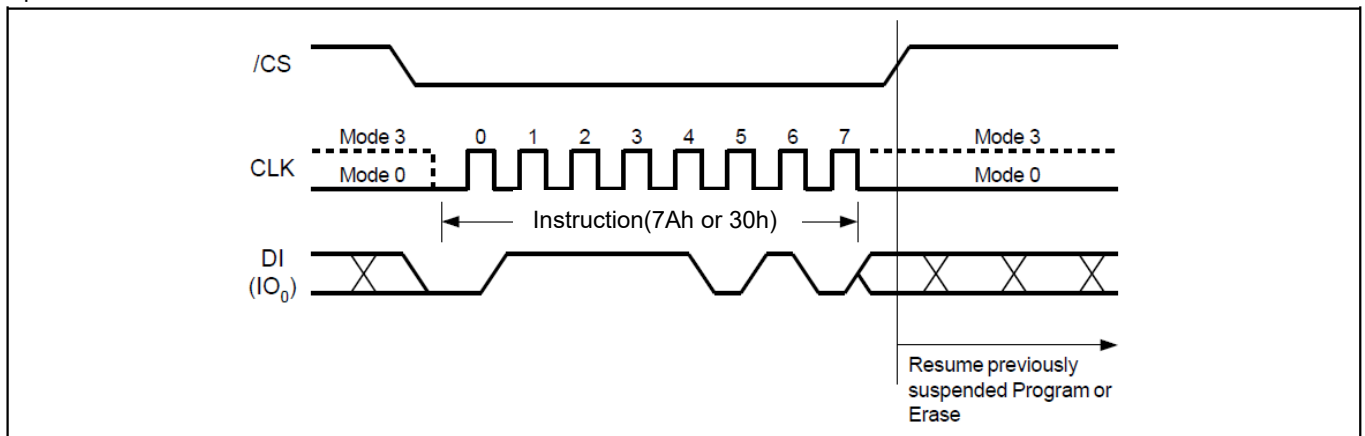

Figure28. Program/Erase Resume Sequence Diagram



# GT25Q40/20/10/05D

## 9.30 Enable Reset (66H) and Reset (99H)

If the Reset command is accepted, any on-going internal operation will be terminated and the device will return to its default power-on state and lose all the current volatile settings, such as Volatile Status Register bits, Write Enable Latch status (WEL), Program/Erase Suspend status, Read Parameter setting (P7-P0), Deep Power Down Mode, Continuous Read Mode bit setting (M7-M0) and Wrap Bit Setting (W6-W4).

The “Enable Reset (66H)” and the “Reset (99H)” commands can be issued in either SPI mode. The “Reset (99H)” command sequence as follow: CS# goes low → Sending Enable Reset command → CS# goes high → CS# goes low → Sending Reset command → CS# goes high. Once the Reset command is accepted by the device, the device will take approximately Trst/Trst\_E to reset. During this period, no command will be accepted. Data corruption may happen if there is an on-going or suspended internal Erase or Program operation when Reset command sequence is accepted by the device. It is recommended to check the BUSY bit and the SUS bit in Status Register before issuing the Reset command sequence.

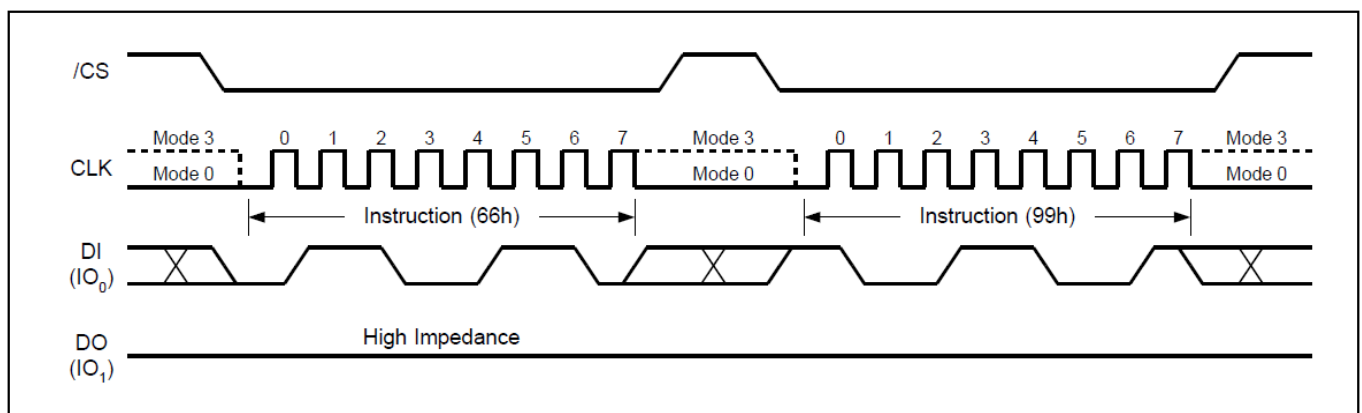

Figure29. Enable Reset and Reset Instruction Sequence



# GT25Q40/20/10/05D

## 9.31 Read SFDP Register (5Ah)

The Serial Flash Discoverable Parameter (SFDP) standard provides a consistent method of describing the functional and feature capabilities of serial flash devices in a standard set of internal parameter tables. These parameter tables can be interrogated by host system software to enable adjustments needed to accommodate divergent features from multiple vendors. The concept is similar to the one found in the Introduction of JEDEC Standard, JESD68 on CFI. SFDP is a standard of JEDEC Standard No.216.

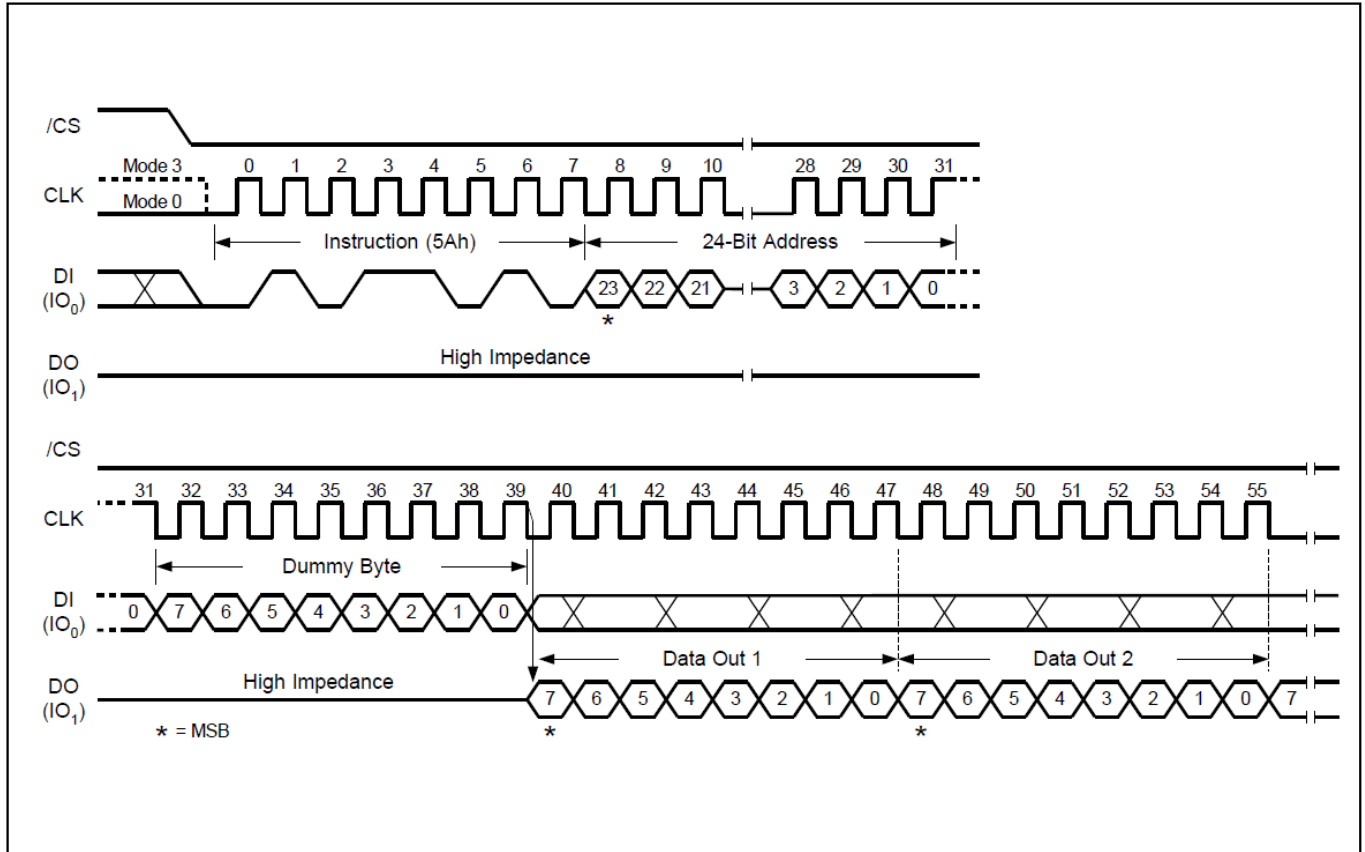

Figure 30. Read SFDP Register Instruction Sequence Diagram(standard SPI mode only)



# GT25Q40/20/10/05D

## Signature and Parameter Identification Data Values

Description	Byte Add(H)	Bit Add	Data	Data
SFDP Signature	00H	7:00	53H	53H
	01H	15:08	46H	46H
	02H	23:16	44H	44H
	02H	31:24	50H	50H
SFDP Minor Revision Number	04H	7:00	06H	06H
SFDP Major Revision Number	05H	15:08	01H	01H
Number of Parameters Headers	06H	23:16	00H	00H
Unused	07H	31:24	FFH	FFH
ID number (JEDEC)	08H	7:00	00H	00H
Parameter Table Minor Revision Number	09H	15:08	06H	06H
Parameter Table Major Revision Number	0AH	23:16	01H	01H
Parameter Table Length (in double word)	0BH	31:24	0FH	0FH
Parameter Table Pointer (PTP)	0CH	7:00	30H	30H
	0DH	15:08	00H	00H
	0EH	23:16	00H	00H
Unused	0FH	31:24	FFH	FFH
ID Number LSB (Giantec Manufacturer ID)	10H	7:00	C4H	C4H
Parameter Table Minor Revision Number	11H	15:08	00H	00H
Parameter Table Major Revision Number	12H	23:16	01H	01H
Parameter Table Length (in double word)	13H	31:24	03H	03H
Parameter Table Pointer (PTP)	14H	7:00	90H	90H
	15H	15:08	00H	00H
	16H	23:16	00H	00H
Unused	17H	31:24:00	FFH	FFH



# GT25Q40/20/10/05D

Description	Byte Add(H)	Bit Add	Data	Data
Unuse	.	.	FFH	FFH
Block/Sector Erase Size	30H	01:00	01b	E5H
Write Granularity		02	1b	
Write Enable Instruction Requested for Writing to Volatile Status Registers		03	0b	
Write Enable Opcode Select for Writing to Volatile Status Registers		04	0b	
Unused		07:05	111b	
4KB Erase Opcode	31H	15:08	20H	20H
(1-1-2) Fast Read	32H	16	1b	F1H
Address Bytes Number used in addressing flash array		18:17	00b	
Double Transfer Rate (DTR) clocking		19	0b	
(1-2-2) Fast Read		20	1b	
(1-4-4) Fast Read		21	1b	
(1-1-4) Fast Read		22	1b	
Unused		23	1b	
Unused	33H	31:24	FFH	FFH
Flash Memory Density	37H:34H	31:00	003FFFFFFH(4Mb) 001FFFFFFH(2Mb) 000FFFFFFH(1Mb) 0007FFFFFFH(512Kb)	
(1-4-4) Fast Read Number of Wait states	38H	04:00	00100b	44H
(1-4-4) Fast Read Number of Mode Bits		07:05	010b	
(1-4-4) Fast Read Opcode	39H	15:08	EBH	EBH



# GT25Q40/20/10/05D

Description	Byte Add(H)	Bit Add	Data	Data
(1-1-4) Fast Read Number of Wait states	3AH	20:16	01000b	08H
(1-1-4) Fast Read Number of Mode Bits		23:21	000b	
(1-1-4) Fast Read Opcode	3BH	31:24	6BH	6BH
(1-1-2) Fast Read Number of Wait states	3CH	04:00	01000b	08H
(1-1-2) Fast Read Number of Mode Bits		07:05	000b	
(1-1-2) Fast Read Opcode	3DH	15:08	3BH	3BH
(1-2-2) Fast Read Number of Wait states	3EH	20:16	00000b	80H
(1-2-2) Fast Read Number of Mode Bits		23:21	100b	
(1-2-2) Fast Read Opcode	3FH	31:24	BBH	BBH
(2-2-2) Fast Read	40H	00	0b	EEH
Unused		03:01	111b	
(4-4-4) Fast Read		04	0b	
Unused		07:05	111b	
Unused	43H:41H	31:08	0xFFH	0xFFH
Unused	45H:44H	15:00	0xFFH	0xFFH
(2-2-2) Fast Read Number of Wait states	46H	20:16	00000b	00H
(2-2-2) Fast Read Number of Mode Bits		23:21	000b	
(2-2-2) Fast Read Opcode	47H	31:24	FFH	FFH
Unused	49H:48H	15:00	FFFFH	FFFFH
(4-4-4) Fast Read Number of Wait states	4AH	20:16	00000b	00H
(4-4-4) Fast Read Number of Mode Bits		23:21	000b	
(4-4-4) Fast Read Opcode	4BH	31:24	FFH	FFH
Sector Type 1 Size	4CH	07:00	0CH	0CH
Sector Type 1 erase Opcode	4DH	15:08	20H	20H
Sector Type 2 Size	4EH	23:16	0FH	0FH



# GT25Q40/20/10/05D

Description	Byte Add(H)	Bit Add	Data	Data
Sector Type 2 erase Opcode	4FH	31:24	52H	52H
Sector Type 3 Size	50H	07:00	10H	10H
Sector Type 3 erase Opcode	51H	15:08	D8H	D8H
Sector Type 4 Size	52H	23:16	00H	00H
Sector Type 4 erase Opcode	53H	31:24	00H	00H
Multiplier from typical erase time to maximum erase time	57:54h	3:0	0000b	04081020H
Sector Type 1 ERASE time (typ)		8:4	00010b	
		10:9	00b	
Sector Type 2 ERASE time (typ)		15:11	00010b	
		17:16	00b	
Sector Type 3 ERASE time (typ)		22:18	00010b	
		24:23	00b	
Sector Type 4 ERASE time (typ)		29:25	00010b	
	31:30	00b		
Multiplier from typical time to maximum time for page or byte PROGRAM	58h	3:0	0000b	80H
Page size		7:4	1000b	
Page Program Typical time	5Ah:59h	12:8	10011b	EF73H
		13	1b	
Byte Program Typical time, first byte		17:14	1101b	
		18	1b	
Byte Program Typical time, additional byte		22:19	1101b	
		23	1b	
Chip Erase, Typical time	5Bh	28:24	00000b	80H
Units		30:29	00b	
Reserved		31	1b	
Prohibited Operations During Program Suspend	5Ch	3:0	1100b	ECH
Prohibited Operations During Erase Suspend		7:4	1110b	
Reserved	5Eh:5Dh	8	0b	1662H
Program Resume to Suspend Interval		12:9	0001b	
Suspend in-progress program max latency		17:13	10011b	
		19:18	01b	
Erase Resume to Suspend Interval		23:20	0001b	



# GT25Q40/20/10/05D

Description	Byte Add(H)	Bit Add	Data	Data
Suspend in-progress erase max latency	5Fh	28:24	10011b	33H
		30:29	01b	
Suspend /Resume supported		31	0b	
Program Resume Instruction	60h	7:0	7Ah	7Ah
Program Suspend Instruction	61h	15:8	75h	75h
Resume Instruction	62h	23:16	7Ah	7Ah
Suspend Instruction	63h	31:24	75h	75h
Reserved	64h	1:0	00b	F4H
Status Register Polling Device Busy		7:2	111101b	
Exit Deep Power-down to next operation delay	67h:65h	12:8	00010b	5CD5A2H
Exit Deep Power-down to next operation delay Units		14:13	01b	
Exit Deep Power-down Instruction		22:15	ABh	
Enter Deep Power-down Instruction		30:23	B9h	
Deep Power-down Supported		31	0b	
4-4-4 mode disable sequences (QPIDI)	69h:68h	3:0	0000b	0600H
4-4-4 mode enable sequences (QPIEN)		8:4	00000b	
0-4-4 Mode Supported		9	1b	
0-4-4 Mode Exit Method		15:10	000001b	
0-4-4 Mode Entry Method:	6Ah	19:16	1100b	5CH
Quad Enable Requirements (QER)		22:20	101b	
Hold or RESET Disable		23	0b	
Reserved	6Bh	31:24	FFh	FFh
Volatile or Non-Volatile Register and Write Enable Instruction for Status Register 1	6Ch	6:0	0001000b	08H
Reserved		7	0b	
Soft Reset and Rescue Sequence Support	6Eh:6Dh	13:8	010000b	0010H
Exit 4-Byte Addressing		23:14	0000000000b	
Enter 4-Byte Addressing	6Fh	31:24	00h	00h
Vcc Supply Maximum Voltage	91H:90H	15:00	3600H	3600H
Vcc Supply Minimum Voltage	93H:92H	31:16	1650H	1650H



# GT25Q40/20/10/05D

Description	Byte Add(H)	Bit Add	Data	Data
HW Reset# pin	95H:94H	00	0b	F99EH
HW Hold# pin		01	1b	
Deep Power Down Mode		02	1b	
SW Reset		03	1b	
SW Reset Opcode		11:04	99H	
Program Suspend/Resume		12	1b	
Erase Suspend/Resume		13	1b	
Unused		14	1b	
Wrap-Around Read mode		15	1b	
Wrap-Around Read mode Opcode		96H	23:16	
Wrap-Around Read data length	97H	31:24	64H	64H

Individual block lock	9BH:98H	00	0b	CBFCH	
Individual block lock bit (Volatile/Nonvolatile)		01	0b		
Individual block lock Opcode		09:02	FFH		
Individual block lock Volatile protect bit default protect status		10	0b		
Secured OTP		11	1b		
Read Lock		12	0b		
Permanent Lock		13	0b		
Unused		15:14	11b		
Unused		31:16	FFFFH		FFFFH
Unused		.	.		FFH
Unused	FFH	FFH	FFH	FFH	



# GT25Q40/20/10/05D

## 9.32 Erase Security Registers (44h)

The GT25Q40/20/10/05D offers four 256-byte Security Registers which can be erased and programmed individually. These registers may be used by the system manufacturers to store security and other important information separately from the main memory array.

The Erase Security Register instruction is similar to the Sector Erase instruction. A Write Enable instruction must be executed before the device will accept the Erase Security Register Instruction (Status Register bit WEL must equal 1). The instruction is initiated by driving the /CS pin low and shifting the instruction code “44h” followed by a 24-bit address (A23-A0) to erase the security registers.

ADDRESS	A23-A16	A15-A9	A8-A0
Security Register #1,#2	00h	0000000b	Don' t Care
Security Register #3,#4	00h	0000001b	Don' t Care

The Erase Security Register instruction sequence is shown in Figure 31. The /CS pin must be driven high after the eighth bit of the last byte has been latched. If this is not done the instruction will not be executed. After /CS is driven high, the self-timed Erase Security Register operation will commence for a time duration of Tse (See AC Characteristics). While the Erase Security Register cycle is in progress, the Read Status Register instruction may still be accessed for checking the status of the BUSY bit. The BUSY bit is a 1 during the erase cycle and becomes a 0 when the cycle is finished and the device is ready to accept other instructions again. After the Erase Security Register cycle has finished the Write Enable Latch (WEL) bit in the Status Register is cleared to 0. The Security Register Lock Bits LB in the Status Register-2 can be used to OTP protect the security registers. Once a lock bit is set to 1, the corresponding security register will be permanently locked, Erase Security Register instruction to that register will be ignored.

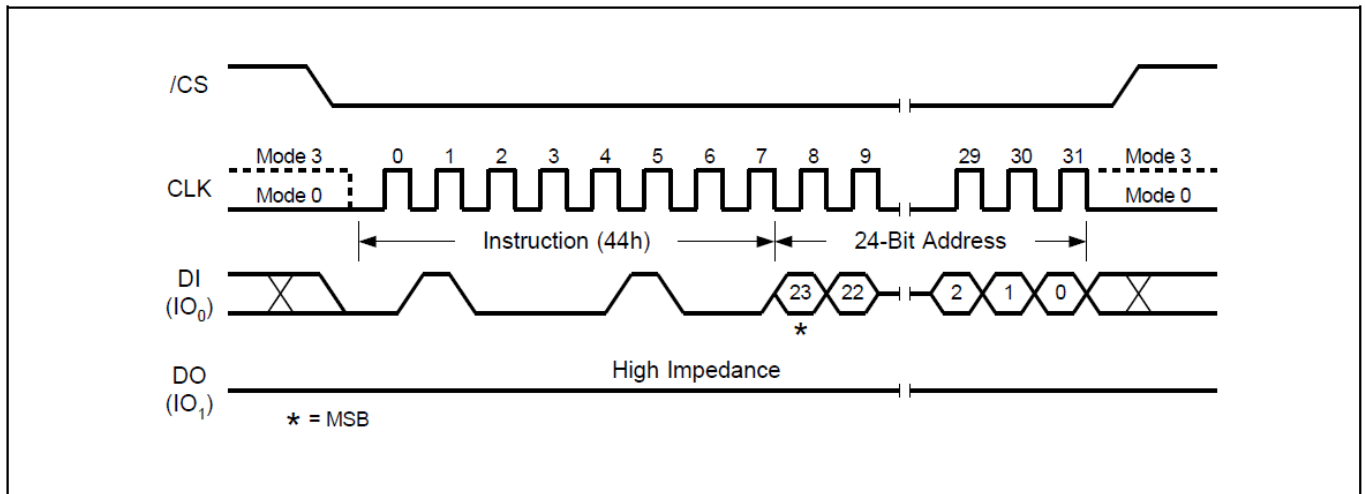

Figure 31. Erase Security Registers Instruction (standard SPI Mode only)



# GT25Q40/20/10/05D

## 9.33 Program Security Registers (42h)

The Program Security Register instruction is similar to the Page Program instruction. It allows from one byte to 256 bytes of security register data to be programmed at previously erased (FFh) memory locations. A Write Enable instruction must be executed before the device will accept the Program Security Register Instruction (Status Register bit WEL= 1). The instruction is initiated by driving the /CS pin low then shifting the instruction code “42h” followed by a 24-bit address (A23-A0) and at least one data byte, into the DI pin. The /CS pin must be held low for the entire length of the instruction while data is being sent to the device.

ADDRESS	A23-A16	A15-A8	A7-A0
Security Register #1	00h	00H	Byte Address
Security Register #2	00h	01H	Byte Address
Security Register #3	00h	02H	Byte Address
Security Register #4	00h	03H	Byte Address

The Program Security Register instruction sequence is shown in Figure 32. The Security Register Lock Bits LB in the Status Register-2 can be used to OTP protect the security registers. Once a lock bit is set to 1, the corresponding security register will be permanently locked, Program Security Register instruction to that register will be ignored

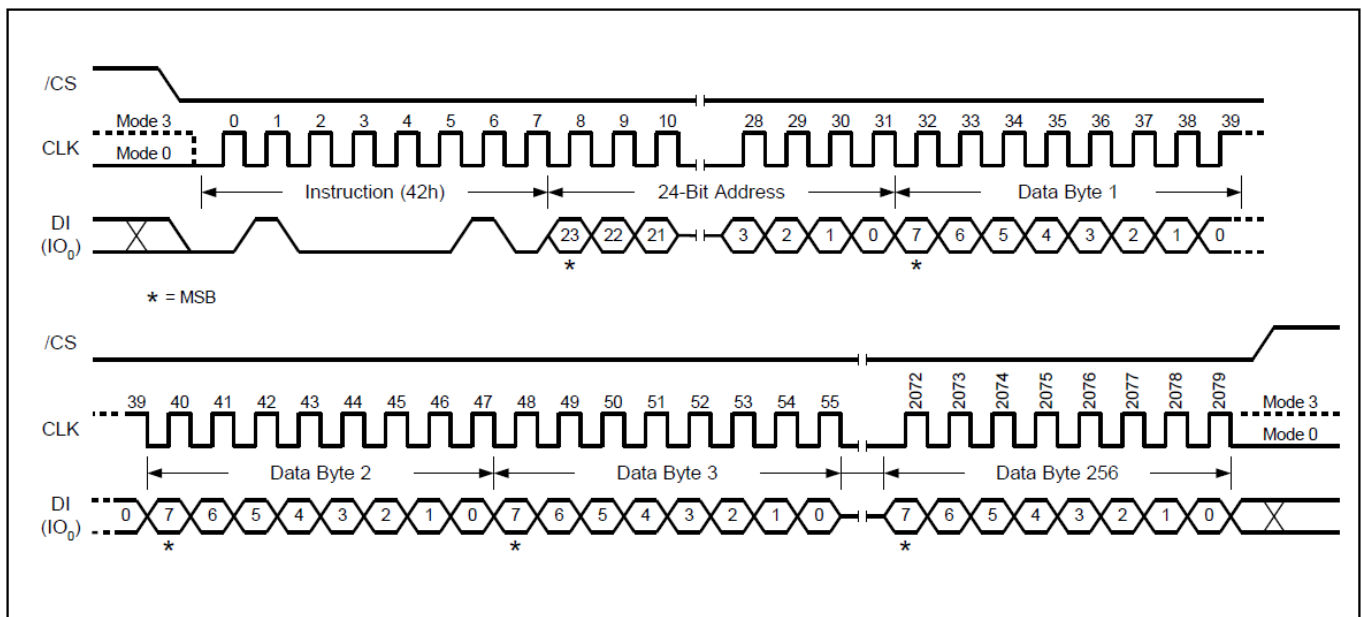

Figure 32. Program Security Registers Instruction (standard SPI Mode only)



# GT25Q40/20/10/05D

## 9.34 Read Security Registers (48h)

The Read Security Register instruction is similar to the Fast Read instruction and allows one or more data bytes to be sequentially read from one of the three security registers. The instruction is initiated by driving the /CS pin low and then shifting the instruction code “48h” followed by a 24-bit address (A23-A0) and eight “dummy” clocks into the DI pin. The code and address bits are latched on the rising edge of the CLK pin. After the address is received, the data byte of the addressed memory location will be shifted out on the DO pin at the falling edge of CLK with most significant bit (MSB) first. The byte address is automatically incremented to the next byte address after each byte of data is shifted out. Once the byte address reaches the last byte of the register (byte FFh), it will reset to 00h, the first byte of the register, and continue to increment. The instruction is completed by driving /CS high. The Read Security Register instruction sequence is shown in Figure 33. If a Read Security Register instruction is issued while an Erase, Program or Write cycle is in process (BUSY=1) the instruction is ignored and will not have any effects on the current cycle. The Read Security Register instruction allows clock rates from D.C. to a maximum of FR (see AC Electrical Characteristics).

ADDRESS	A23-A16	A15-A8	A7-A0
Security Register #1	00h	00H	Byte Address
Security Register #2	00h	01H	Byte Address
Security Register #3	00h	02H	Byte Address
Security Register #4	00h	03H	Byte Address

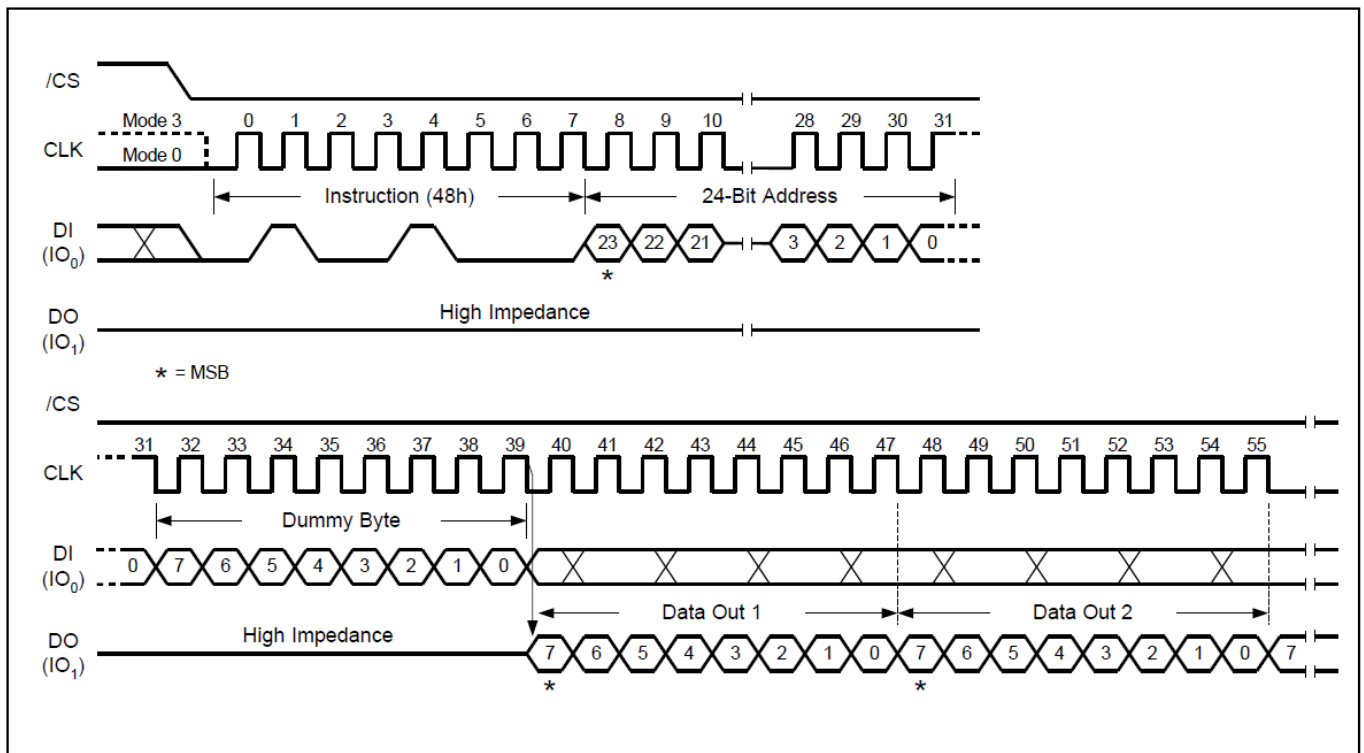

Figure 33. Read Security Registers Instruction (standard SPI Mode only)



# GT25Q40/20/10/05D

## 10 Package Information

### 10.1 Package SOP8 208MIL

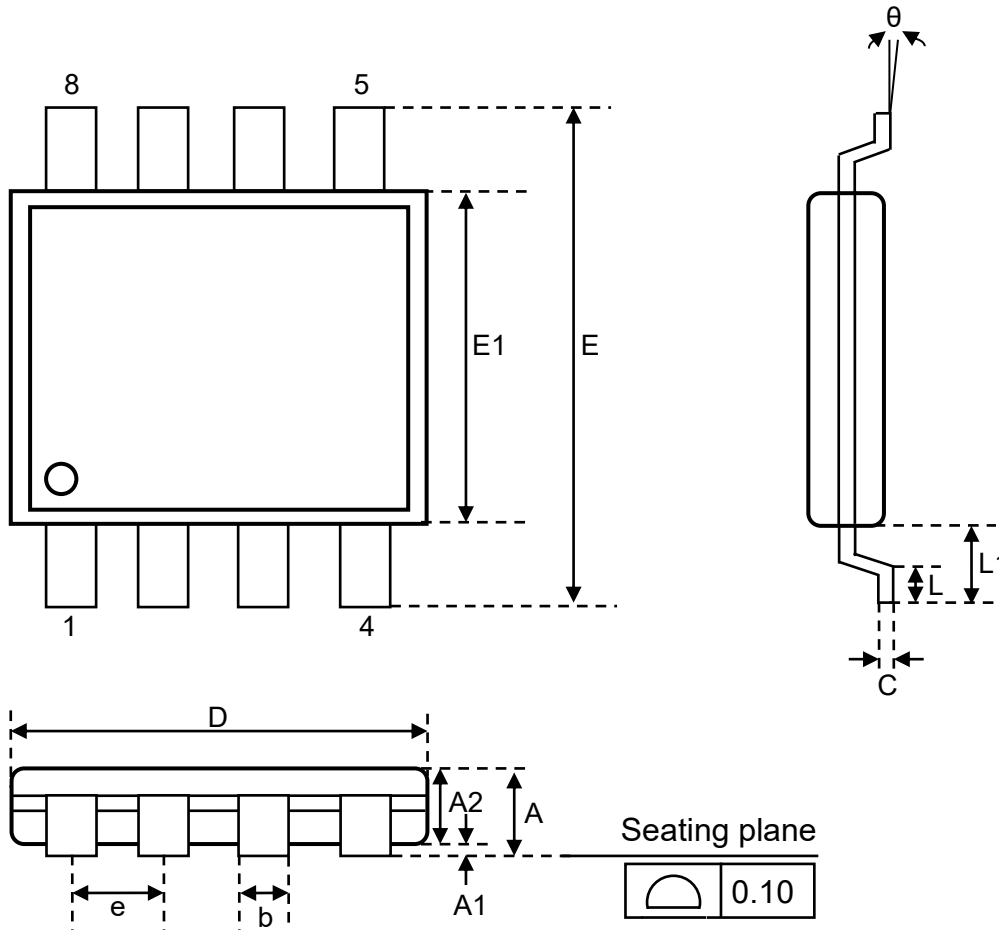

Symbol	mm			Inch		
	Min	Nom	Max	Min	Nom	Max
A	1.75	1.95	2.16	0.069	0.077	0.085
A1	0.05	0.15	0.25	0.002	0.006	0.010
A2	1.70	1.80	1.91	0.067	0.071	0.075
b	0.31	0.41	0.51	0.012	0.016	0.020
C	0.18	0.21	0.25	0.007	0.008	0.010
D	5.13	5.23	5.33	0.202	0.206	0.210
E	7.70	7.90	8.10	0.303	0.311	0.319
E1	5.18	5.28	5.38	0.204	0.208	0.212
e		1.27			0.050	
L	0.50	0.67	0.85	0.020	0.026	0.033
L1	1.21	1.31	1.41	0.048	0.052	0.056
$\theta$	0°	5°	8°	0°	5°	8°



# GT25Q40/20/10/05D

## 10.2 Package SOP8 150MIL

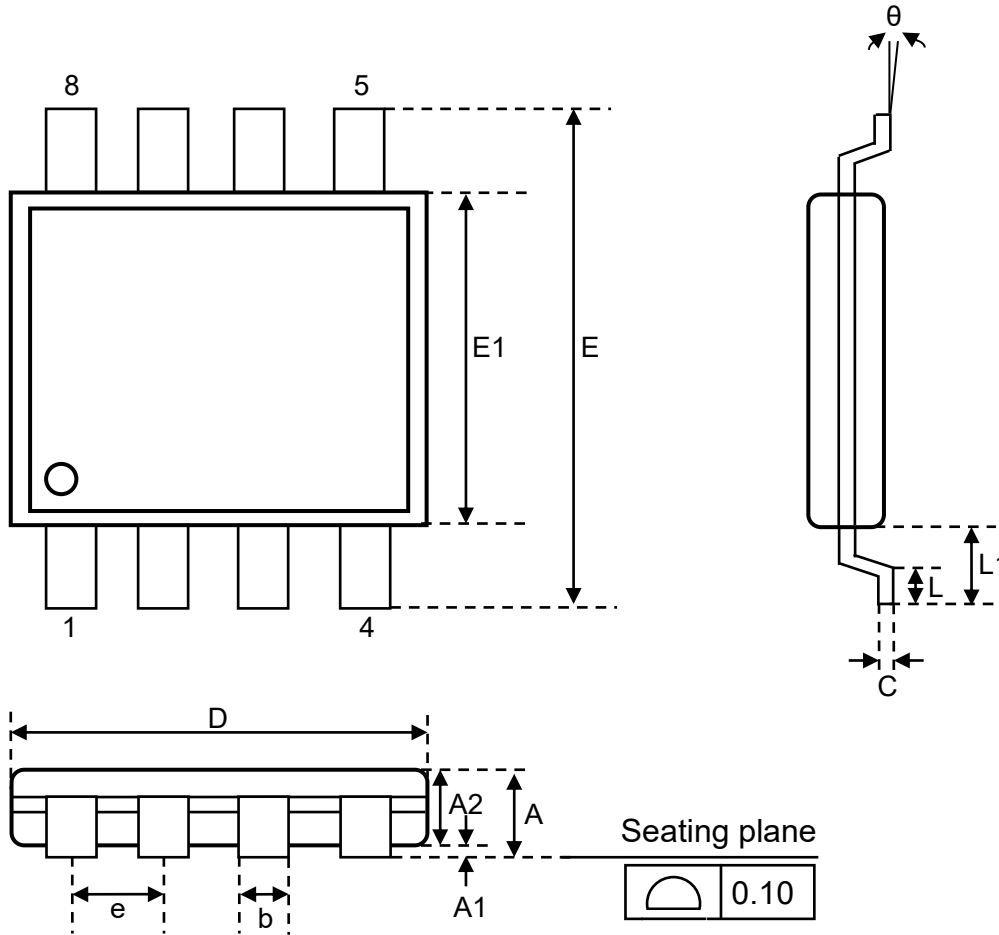

Symbol	mm			Inch		
	Min	Nom	Max	Min	Nom	Max
A	1.35	-	1.75	0.053	-	0.069
A1	0.10	-	0.25	0.004	-	0.010
A2	1.35	-	1.55	0.053	-	0.061
b	0.31	-	0.51	0.012	0.016	0.020
C	0.10	-	0.25	0.004	-	0.010
D	4.80	4.90	5.03	0.189	0.193	0.197
E	5.80	6.00	6.20	0.228	0.236	0.244
E1	3.80	3.90	4.00	0.149	0.154	0.158
e	-	1.27	-	-	0.050	-
L	0.40	-	0.90	0.016	-	0.035
L1	0.85	1.06	1.27	0.033	0.042	0.050
θ	0°	-	8°	0°	-	8°



# GT25Q40/20/10/05D

## 10.3 Package TSSOP8L (173mil)

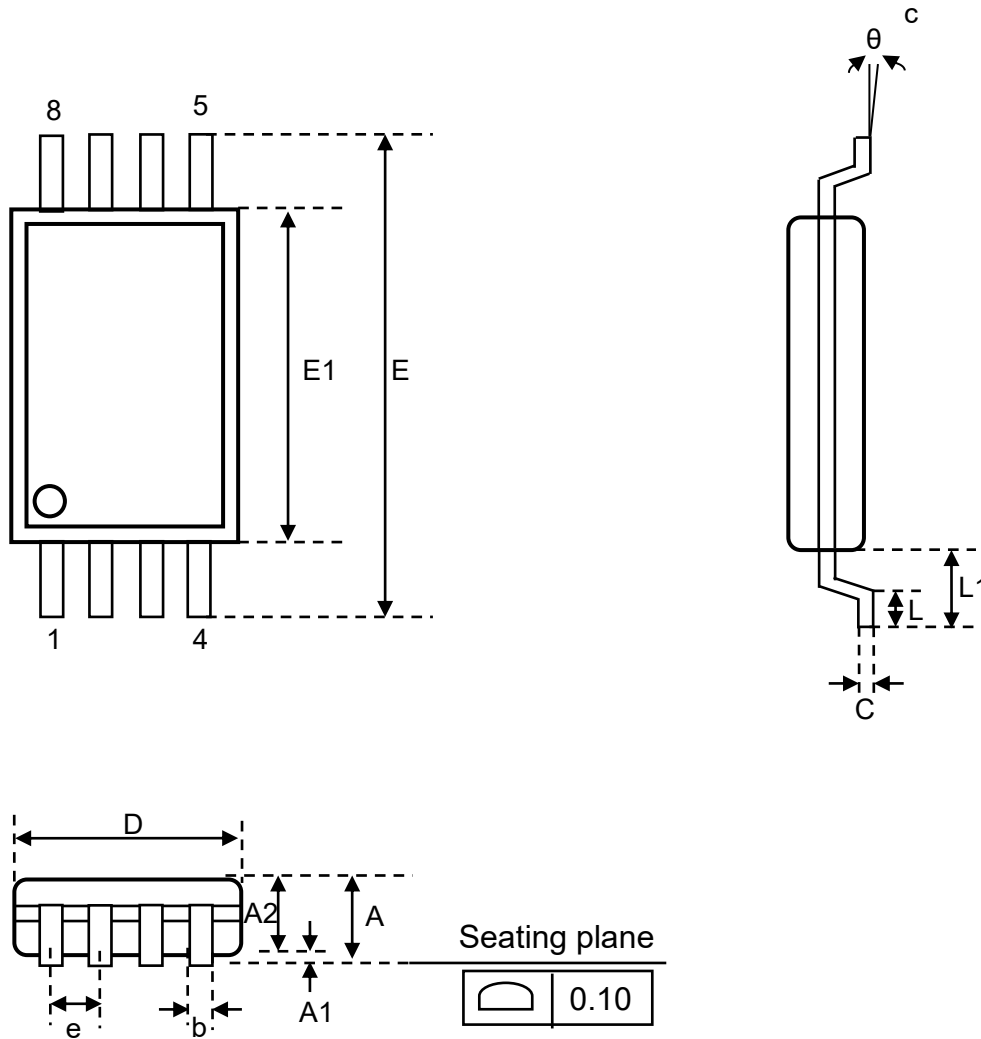

Symbol	mm			Inch		
	Min	Nom	Max	Min	Nom	Max
A	-	-	1.20	-	-	0.047
A1	0.05	0.10	0.15	0.002	0.004	0.006
A2	0.80	0.90	1.00	0.031	0.035	0.039
b	0.20	0.25	0.30	0.008	0.010	0.012
c	0.10	0.15	0.20	0.004	0.006	0.008
D	2.90	3.00	3.10	0.114	0.118	0.112
E	6.30	6.40	6.50	0.248	0.252	0.256
E1	4.30	4.40	4.50	0.169	0.173	0.177
e	-	0.65	-	-	0.026	-
L	0.45	0.60	0.75	0.018	0.024	0.030
L1	0.85	1.00	1.15	0.033	0.039	0.045
θ	0	4	8	0	4	8

Note:

- The exposed metal pad area on the bottom of the package is floating.



# GT25Q40/20/10/05D

## 10.4 Package WSON8 (6\*5mm)

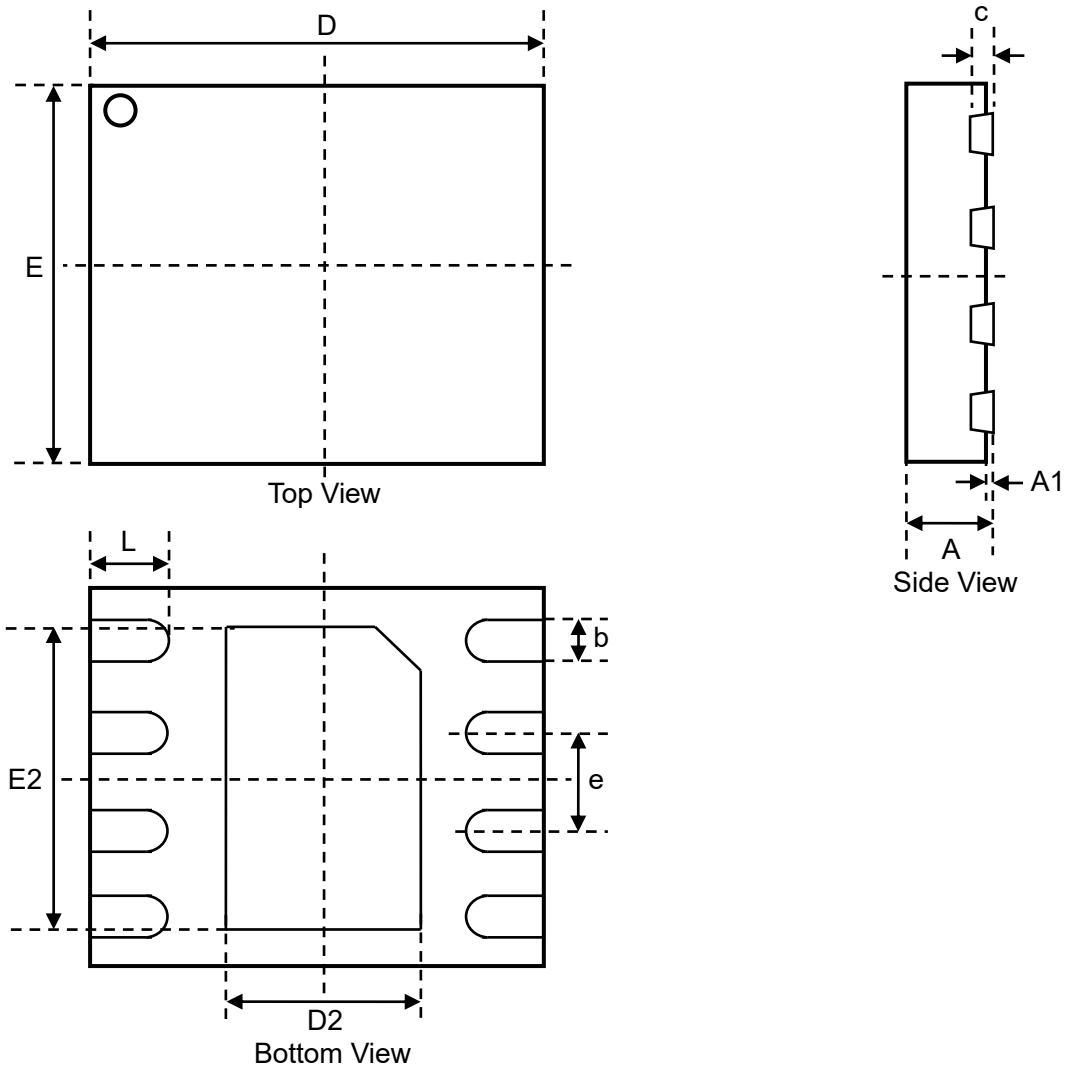

Symbol	mm			Inch		
	Min	Nom	Max	Min	Nom	Max
A	0.70	0.75	0.80	0.028	0.030	0.031
A1	0.00	0.02	0.05	0.000	0.001	0.002
c	0.180	0.203	0.250	0.007	0.008	0.010
b	0.35	0.40	0.50	0.014	0.016	0.020
D	5.90	6.00	6.10	0.232	0.236	0.240
D2	3.30	3.40	3.50	0.130	0.134	0.138
E	4.90	5.00	5.10	0.193	0.197	0.201
E2	3.90	4.00	4.10	0.154	0.157	0.161
e		1.27			0.05	
L	0.50	0.60	0.75	0.020	0.024	0.030

Note:

13. The exposed metal pad area on the bottom of the package is floating.



# GT25Q40/20/10/05D

## 10.5 Package WSON8 (4\*3mm)

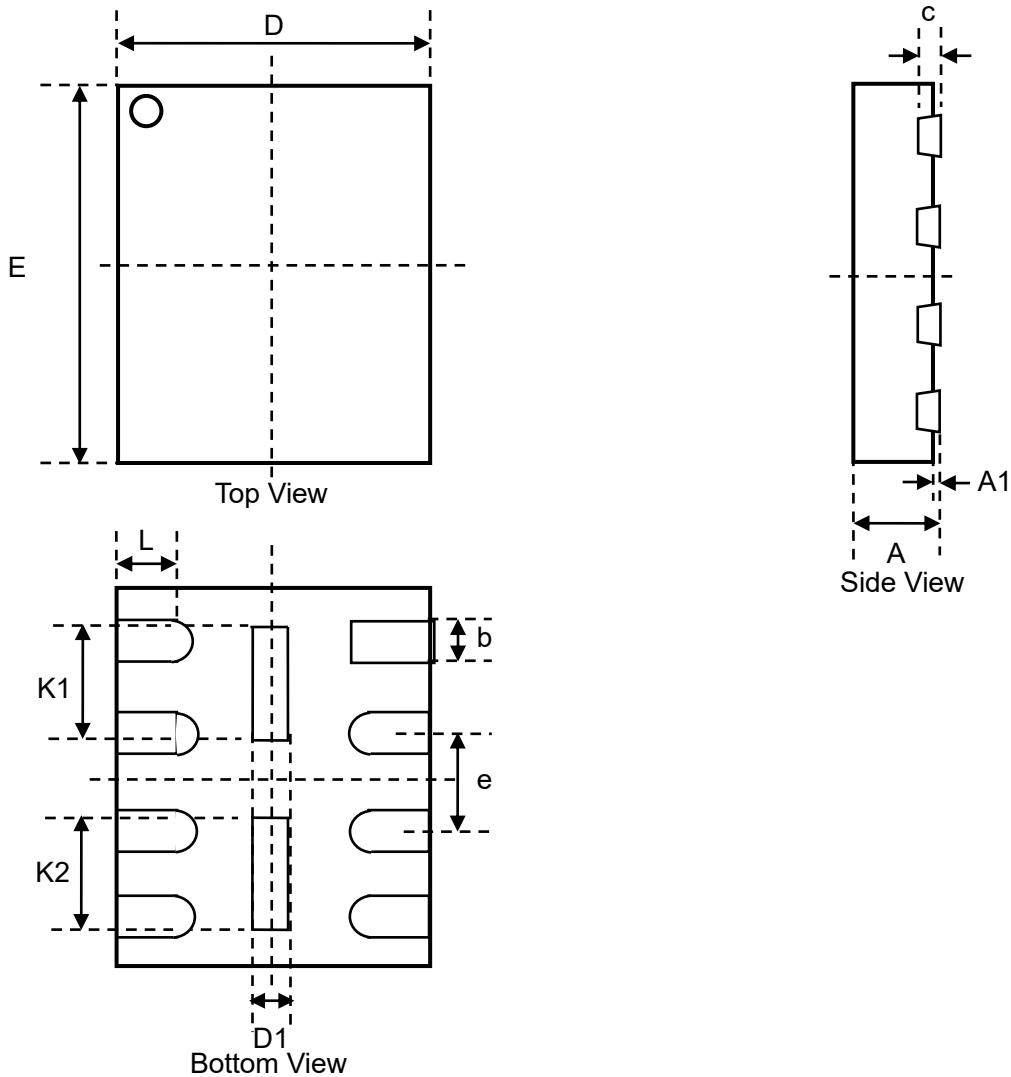

Symbol	mm			Inch		
	Min	Nom	Max	Min	Nom	Max
A	0.50	0.55	0.60	0.020	0.022	0.024
A1	0.00	0.02	0.05		0.001	0.002
c	0.10	0.15	0.20	0.004	0.006	0.008
b	0.25	0.30	0.35	0.010	0.012	0.014
D	2.90	3.00	3.10	0.114	0.118	0.122
D1	0.10	0.20	0.30	0.000	0.001	0.001
E	3.90	4.00	4.10	0.154	0.157	0.161
K1	0.70	0.80	0.90	0.002	0.002	0.002
K2	0.70	0.80	0.90	0.002	0.002	0.002
e		0.80			0.031	
L	0.55	0.60	0.65	0.022	0.024	0.026

Note:

1. The exposed metal pad area on the bottom of the package is floating.



# GT25Q40/20/10/05D

## 10.6 Package USON8 (2\*3mm)

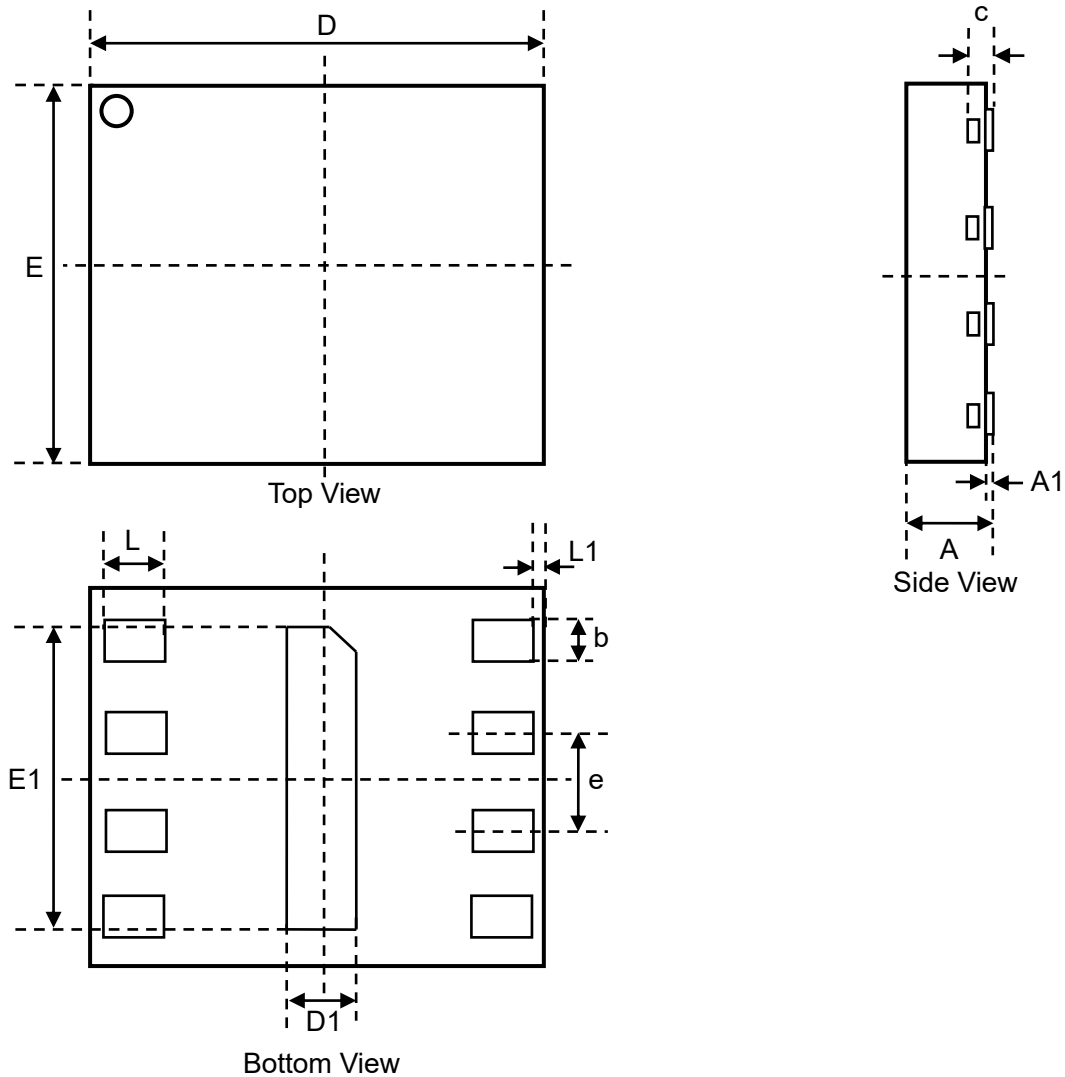

Symbol	mm			Inch		
	Min	Nom	Max	Min	Nom	Max
A	0.40	0.45	0.50	0.016	0.018	0.020
A1	0.00	0.02	0.05		0.001	0.002
c	0.10	0.15	0.20	0.004	0.006	0.008
b	0.20	0.25	0.30	0.008	0.010	0.012
D	2.90	3.00	3.10	0.114	0.118	0.122
D1	0.15	0.20	0.25	0.006	0.008	0.010
E	1.90	2.00	2.10	0.075	0.079	0.083
E1	1.55	1.60	1.65	0.061	0.063	0.065
e		0.50			0.020	
L	0.30	0.35	0.40	0.012	0.014	0.016
L1	0.05	0.10	0.15	0.002	0.004	0.006

Note:

1. The exposed metal pad area on the bottom of the package is floating.



# GT25Q40/20/10/05D

## 10.7 Package 8Pin USON1.5\*1.5

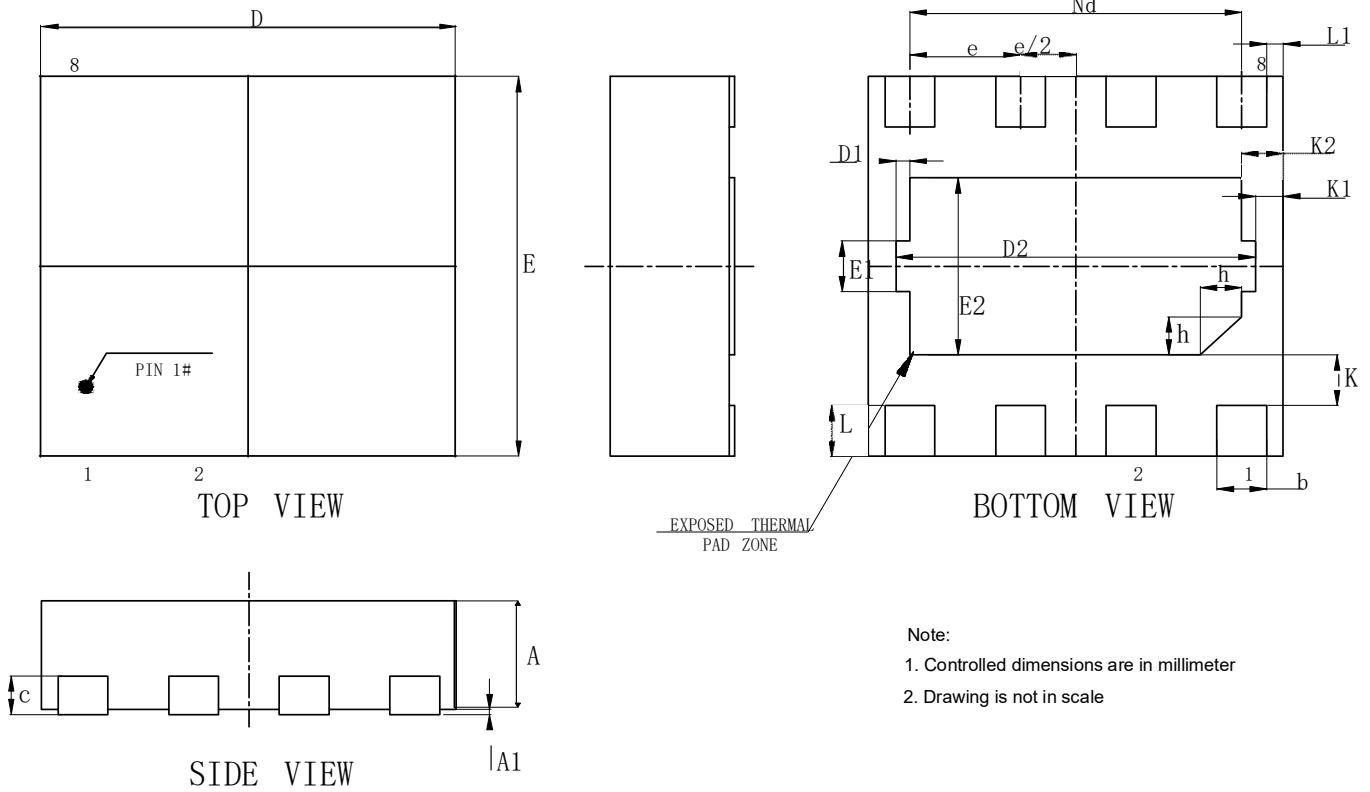

Symbol	mm			Inch		
	Min	Nom	Max	Min	Nom	Max
A	0.400	0.450	0.500	0.016	0.018	0.020
A1	0.000	0.020	0.050	0.000	0.001	0.002
b	0.130	0.180	0.230	0.005	0.007	0.009
c		0.152		--	0.006	--
D	1.450	1.500	1.550	0.057	0.059	0.061
D1		0.050		--	0.002	--
D2	1.200	1.300	1.400	0.047	0.051	0.055
e		0.400		--	0.016	--
Nd		1.200		--	0.047	--
E	1.450	1.500	1.550	0.057	0.059	0.061
E1		0.200		--	0.008	--
E2	0.600	0.700	0.800	0.024	0.028	0.031
L	0.150	0.200	0.250	0.006	0.008	0.010
L1		0.060		--	0.002	--
K		0.200		--	0.008	--
K1		0.100		--	0.004	--
K2		0.150		--	0.006	--
h	0.100	0.150	0.200	0.004	0.006	0.008



# GT25Q40/20/10/05D

## 10.8 Package 6Pin USON1.2\*1.2

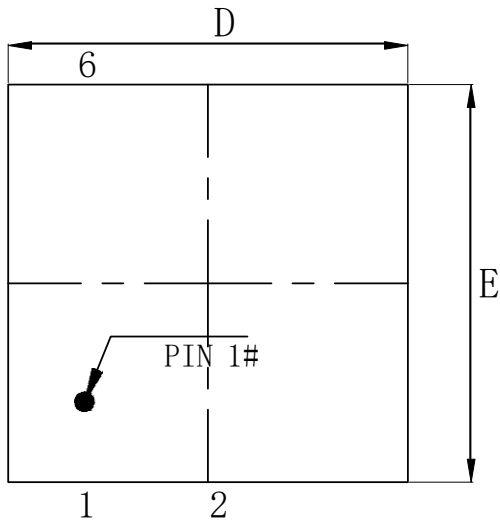

TOP VIEW

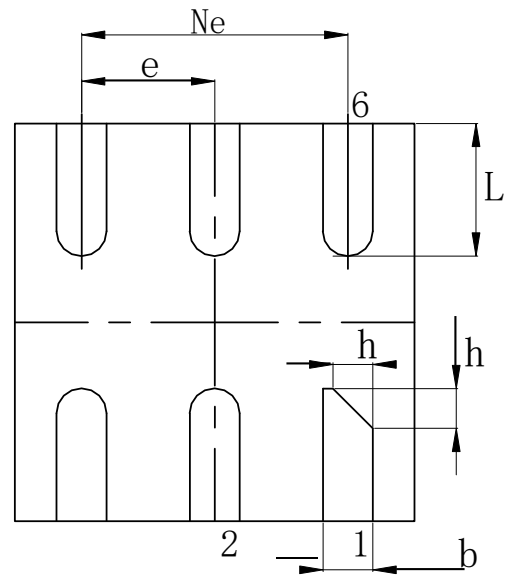

BOTTOM VIEW

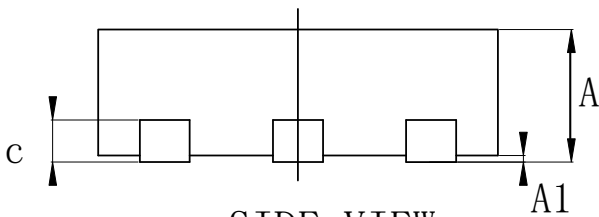

SIDE VIEW

Note:

1. Controlled dimensions are in millimeter
2. Drawing is not in scale

Symbol	mm			Inch		
	Min	Nom	Max	Min	Nom	Max
A	0.320	-	0.410	0.012	--	0.016
A1	0.000	0.020	0.050	0.000	0.001	0.002
b	0.100	0.150	0.200	0.004	0.006	0.008
c		0.127		--	0.005	--
D	1.100	1.200	1.300	0.043	0.047	0.051
e		0.400		--	0.016	--
Ne		0.800		--	0.031	--
E	1.100	1.200	1.300	0.043	0.047	0.051
L	0.320	0.400	0.480	0.013	0.016	0.019
h		0.120		--	0.005	--



# GT25Q40/20/10/05D

## 10.9 Package 6Pin Fan Out CSP

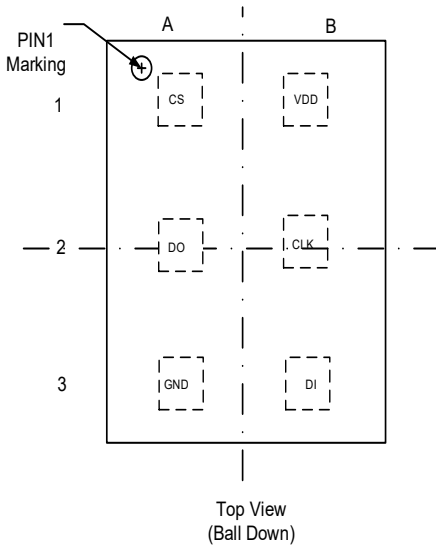
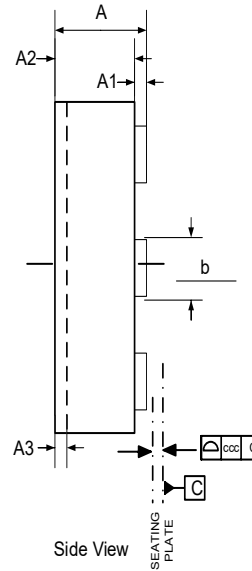
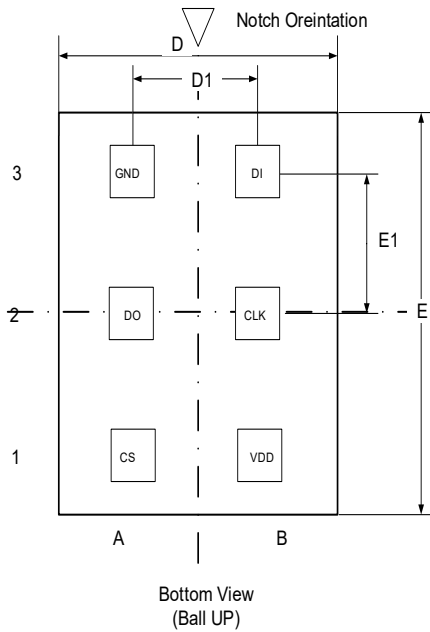

- Note:
1. Controlled dimensions are in millimeter
  2. Drawing is not in scale
  3. With 25um lamination.

Symbol	mm			Inch		
	Min	Nom	Max	Min	Nom	Max
A	0.415	0.450	0.485	0.0163	0.0177	0.0191
A1		0.030		0.0000	0.0012	0.0000
A2	0.395	0.420	0.445	0.0156	0.0165	0.0175
b		0.200		0.0000	0.0079	0.0000
D	0.700	0.725	0.750	0.0276	0.0285	0.0295
D1	--	0.350	--	--	0.0138	--
E	1.200	1.225	1.250	0.0472	0.0482	0.0492
E1	--	0.400	--	--	0.0157	--



# GT25Q40/20/10/05D

## 11 Ordering Information

GT XXX XX X - X XX X X - XX

### Company

GT=Giantec

### Product Family

25Q = SPI Nor Flash,SPI/ Dual/Quad I/O

### Density

05 = 512Kb	80=8Mb	128=128Mb
10 = 1Mb	16=16Mb	256=256Mb
20 = 2Mb	32=32Mb	512=512Mb
40 = 4Mb	64=64Mb	

### Version

D = D Version

### Operation Voltage

L = 1.65V ~ 2.1V    U=1.65V ~ 3.6V    H=2.7~3.6V

### Package Type

W = SOP8 208 mil	TD = USON 1.2x1.2 mm
G = SOP8 150 mil	CF= 0.7*1.2 Fan Out CSP
WS = WSON 6x5 mm	Z = TSSOP8 173mil
WU = WSON 4x3 mm	XKU30 = Sorted and Un-inked KGD
ED = USON 2x3 mm	
VD = USON 1.5x1.5 mm	

### Green Code

L=Pb Free

### Temperature Range

I = Industrial(-40°C to +85°C)  
IE= Industrial(-40°C to +105°C)

### Packing

TR= Tape & Reel



# GT25Q40/20/10/05D

## 12 Valid Part Numbers and Top Side Marking

The following table provides the valid part numbers for the GT25Q40/20/10/05D SPI Flash Memory. Please contact Giantec for specific availability by density and package type.

Density	Package Type	Product Number	Top Side Marking Industry(-40°C~85°C)
4Mb	SOP8 208mil	GT25Q40D-UWLI-TR	YWW 540D-U <u>W</u> LI
	SOP8 150mil	GT25Q40D-UGLI-TR	YWW 540D-U <u>G</u> LI
	TSSOP 173mil	GT25Q40D-UZLI-TR	GT 540D -U <u>Z</u> LI
	WSON 5x6	GT25Q40D-UWSLI-TR	GT 540D -U <u>W</u> SLI
	WSON 4x3	GT25Q40D-UWULI-TR	GT 540DW <u>Y</u> WW
	USON 2x3	GT25Q40D-UEDLI-TR	GT 540D <u>Y</u> WW
	USON 1.5x1.5	GT25Q40D-UVDLI-TR	G4D <u>Y</u> WW
	USON 1.2x1.2	GT25Q40D-UTDLI-TR	G4 <u>Y</u> W
	6Pin Fan Out CSP	GT25Q40D-UCFLI-TR	AYW Q2D
2Mb	SOP8 208mil	GT25Q20D-UWLI-TR	YWW 520D-U <u>W</u> LI
	SOP8 150mil	GT25Q20D-UGLI-TR	YWW 520D-U <u>G</u> LI
	TSSOP 173mil	GT25Q20D-UZLI-TR	GT 520D -U <u>Z</u> LI
	WSON 5x6	GT25Q20D-UWSLI-TR	GT 520D -U <u>W</u> SLI
	WSON 4x3	GT25Q20D-UWULI-TR	GT 520DW <u>Y</u> WW
	USON 2x3	GT25Q20D-UEDLI-TR	GT 520D <u>Y</u> WW
	USON 1.5x1.5	GT25Q20D-UVDLI-TR	G2D <u>Y</u> WW
	USON 1.2x1.2	GT25Q20D-UTDLI-TR	G2 <u>Y</u> W
	6Pin Fan Out CSP	GT25Q20D-UCFLI-TR	AYW Q1D
1Mb	SOP8 208mil	GT25Q10D-UWLI-TR	YWW 510D-U <u>W</u> LI
	SOP8 150mil	GT25Q10D-UGLI-TR	YWW 510D-U <u>G</u> LI
	TSSOP 173mil	GT25Q10D-UZLI-TR	GT 510D -U <u>Z</u> LI
	WSON 5x6	GT25Q10D-UWSLI-TR	GT 510D -U <u>W</u> SLI
	WSON 4x3	GT25Q10D-UWULI-TR	GT 510DW <u>Y</u> WW
	USON 2x3	GT25Q10D-UEDLI-TR	GT 510D <u>Y</u> WW
512Kb	SOP8 208mil	GT25Q05D-UWLI-TR	YWW 505D-U <u>W</u> LI
	SOP8 150mil	GT25Q05D-UGLI-TR	YWW 505D-U <u>G</u> LI
	TSSOP 173mil	GT25Q05D-UZLI-TR	GT 505D -U <u>Z</u> LI
	WSON 5x6	GT25Q05D-UWSLI-TR	GT 505D -U <u>W</u> SLI
	WSON 4x3	GT25Q05D-UWULI-TR	GT 505DW <u>Y</u> WW
	USON 2x3	GT25Q05D-UEDLI-TR	GT 505D <u>Y</u> WW



# GT25Q40/20/10/05D

Density	Package Type	Product Number	Top Side Marking Industry(-40°C~105°C)
4Mb	SOP8 208mil	GT25Q40D-UWLIE-TR	G YWW 540DU <u>W</u> LIE
	SOP8 150mil	GT25Q40D-UGLIE-TR	G YWW 540DU <u>G</u> LIE
	TSSOP 173mil	GT25Q40D-UZLIE-TR	GT 540D U <u>Z</u> LIE YWW
	WSON 5x6	GT25Q40D-UWSLIE-TR	GT 540D U <u>W</u> SR YWW
	WSON 4x3	GT25Q40D-UWULIE-TR	GT 40DEW <u>Y</u> WW
	USON 2x3	GT25Q40D-UEDLIE-TR	GT 40DE <u>Y</u> WW
	USON 1.5x1.5	GT25Q40D-UVDLIE-TR	G4DE <u>Y</u> WW
	USON 1.2x1.2	GT25Q40D-UTDLIE-TR	
	6Pin Fan Out CSP	GT25Q40D-UCFLIE-TR	
2Mb	SOP8 208mil	GT25Q20D-UWLIE-TR	G YWW 520DU <u>W</u> LIE
	SOP8 150mil	GT25Q20D-UGLIE-TR	G YWW 520DU <u>G</u> LIE
	TSSOP 173mil	GT25Q20D-UZLIE-TR	GT 520D U <u>Z</u> LIE YWW
	WSON 5x6	GT25Q20D-UWSLIE-TR	GT 520D U <u>W</u> SR YWW
	WSON 4x3	GT25Q20D-UWULIE-TR	GT 20DEW <u>Y</u> WW
	USON 2x3	GT25Q20D-UEDLIE-TR	GT 20DE <u>Y</u> WW
	USON 1.5x1.5	GT25Q20D-UVDLIE-TR	G2DE <u>Y</u> WW
	USON 1.2x1.2	GT25Q20D-UTDLIE-TR	
	6Pin Fan Out CSP	GT25Q20D-UCFLIE-TR	
1Mb	SOP8 208mil	GT25Q10D-UWLIE-TR	G YWW 510DU <u>W</u> LIE
	SOP8 150mil	GT25Q10D-UGLIE-TR	G YWW 510DU <u>G</u> LIE
	TSSOP 173mil	GT25Q10D-UZLIE-TR	GT 510D U <u>Z</u> LIE YWW
	WSON 5x6	GT25Q10D-UWSLIE-TR	GT 510D U <u>W</u> SR YWW
	WSON 4x3	GT25Q10D-UWULIE-TR	GT 10DEW <u>Y</u> WW
	USON 2x3	GT25Q10D-UEDLIE-TR	GT 10DE <u>Y</u> WW
512Kb	SOP8 208mil	GT25Q05D-UWLIE-TR	G YWW 505DU <u>W</u> LIE
	SOP8 150mil	GT25Q05D-UGLIE-TR	G YWW 505DU <u>G</u> LIE
	TSSOP 173mil	GT25Q05D-UZLIE-TR	GT 505D U <u>Z</u> LIE YWW
	WSON 5x6	GT25Q05D-UWSLIE-TR	GT 505D U <u>W</u> SR YWW
	WSON 4x3	GT25Q05D-UWULIE-TR	GT 05DEW <u>Y</u> WW
	USON 2x3	GT25Q05D-UEDLIE-TR	GT 05DE <u>Y</u> WW



# GT25Q40/20/10/05D

## 13 REVISION HISTORY

Revision	Date	Descriptions
V1.0	Oct.2022	Initial Version
V1.1	Jul.2023	Update 6pin Fan out CSP POD
V1.2	Aug.2023	Update DC&AC
V1.3	Sep.2023	Update Marking
V1.4	Jun.2024	Update DC&AC
V1.5	Nov.2024	Update Fr spec
V1.6	Jan.2025	Update DC&AC, optimize the command table, fix some details.
V1.7	Feb.2025	Add 105°C top marking
V1.8	Jun.2025	Add WSON 4x3 package
V1.9	Jul.2025	Update Fr spec
V2.0	Jan.2026	Update Fr spec
V2.1	Mar.2026	Update Tse, Tbe, Tce, Idpd, ICC1,ICC3 parameter

### Important Notice

Except for customized products which have been expressly identified in the applicable agreement, Giantec's products are designed, developed, and/or manufactured for ordinary business, industrial, personal, and/or household applications only, and not for use in any applications which may, directly or indirectly, cause death, personal injury, or severe property damages. In the event Giantec products are used in contradicted to their target usage above, the buyer shall take any and all actions to ensure said Giantec's product qualified for its actual use in accordance with the applicable laws and regulations; and Giantec as well as it' s suppliers and/or distributors shall be released from any and all liability arisen therefrom.

For the contact and order information, please visit Giantec's Web site at: [http:// www.giantec-semi.com](http://www.giantec-semi.com)